

A fluorescence microscopy image of a cell in mitosis. The cell is stained with three different dyes: blue for DNA (chromosomes), red for tubulin (spindle fibers), and green for actin (cell cortex). The chromosomes are arranged in a metaphase plate in the center, with spindle fibers extending from the poles. The cell is surrounded by a network of actin filaments.

SV-F Génomique

TP : Les divisions cellulaires

BCPST1, Lycée Hoche

<https://actu.epfl.ch/news>

Quantité d'ADN par noyau

Masse de la cellule

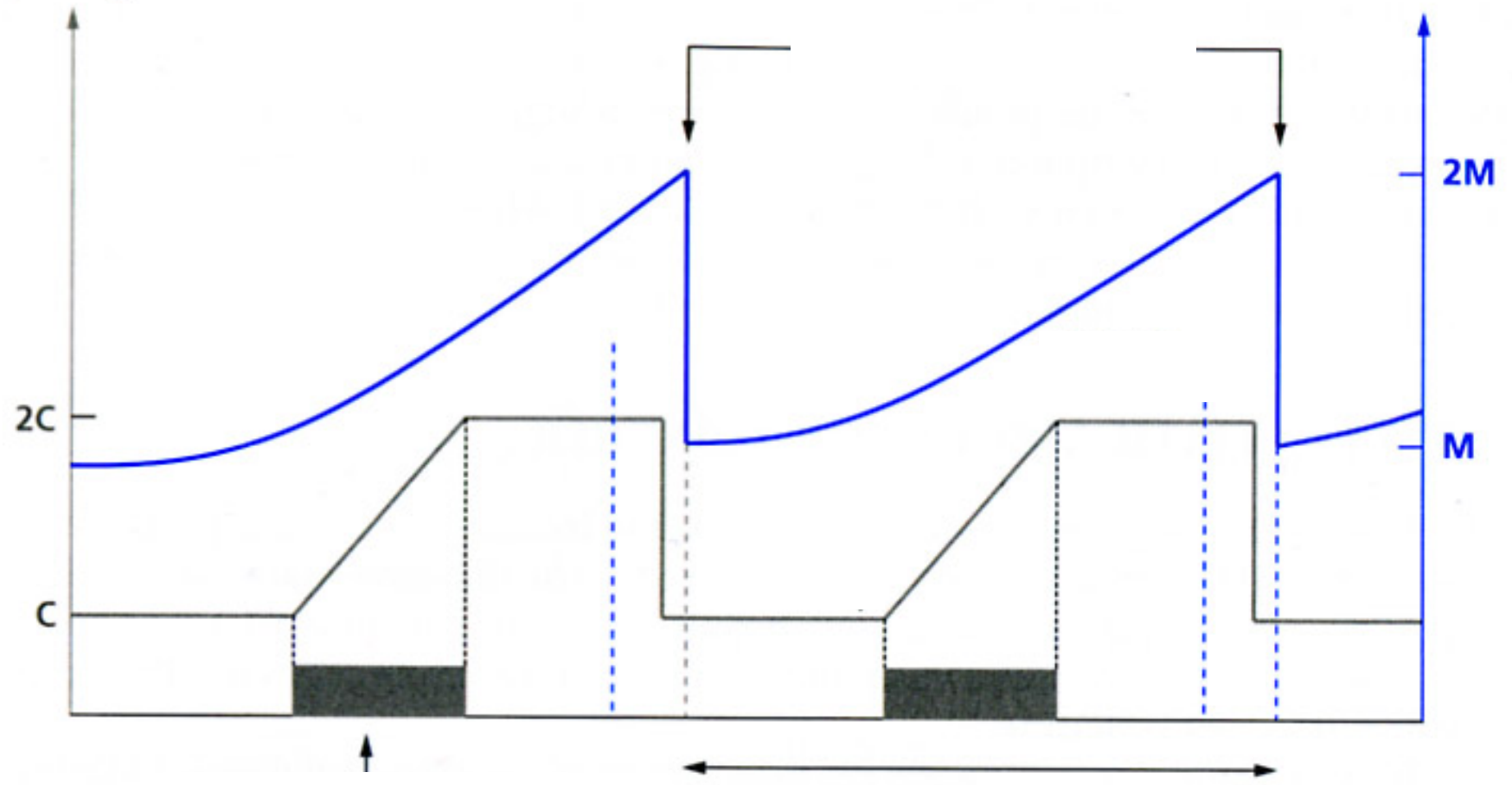

Quantité d'ADN
par noyau

Masse de la cellule

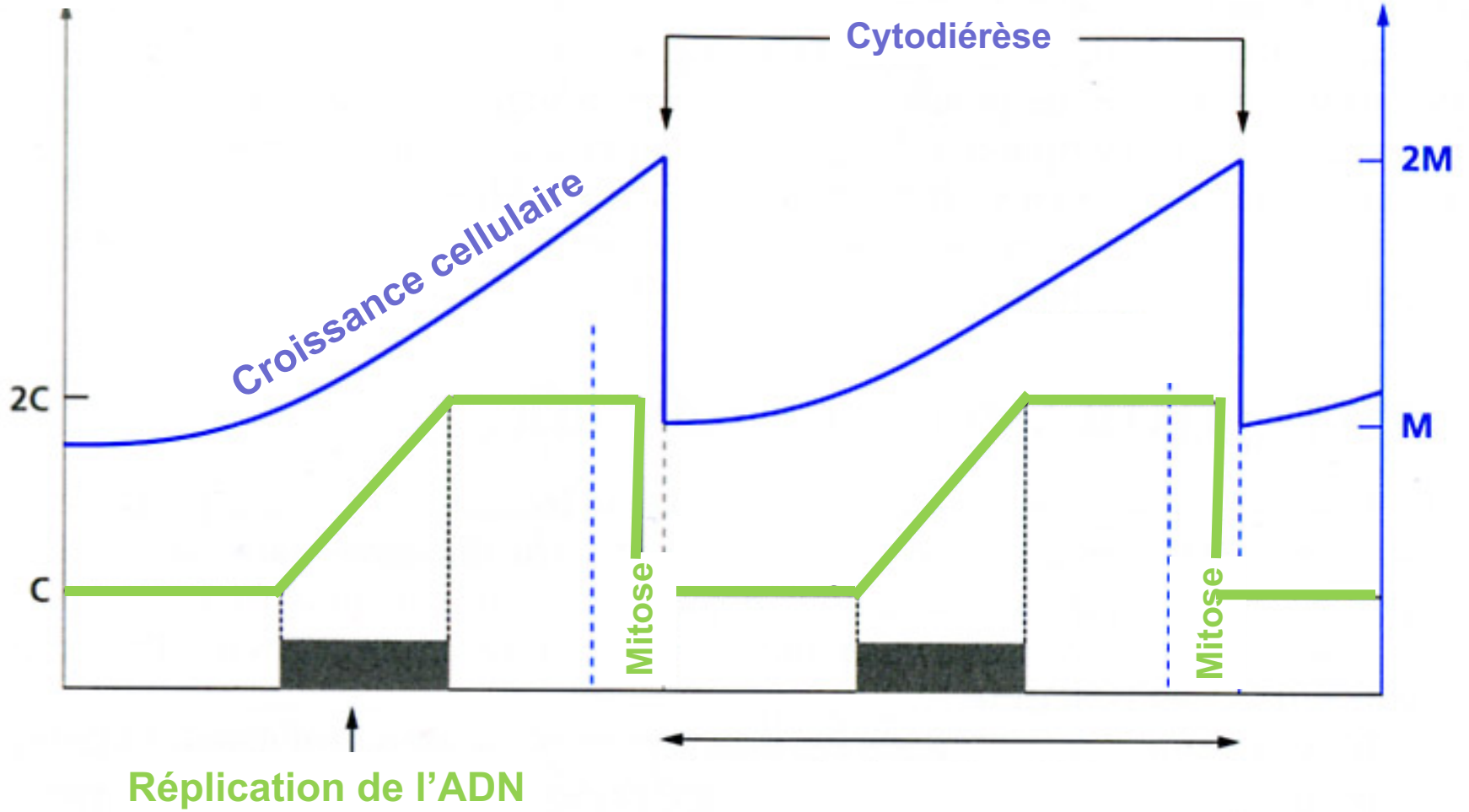

Quantité d'ADN
par noyau

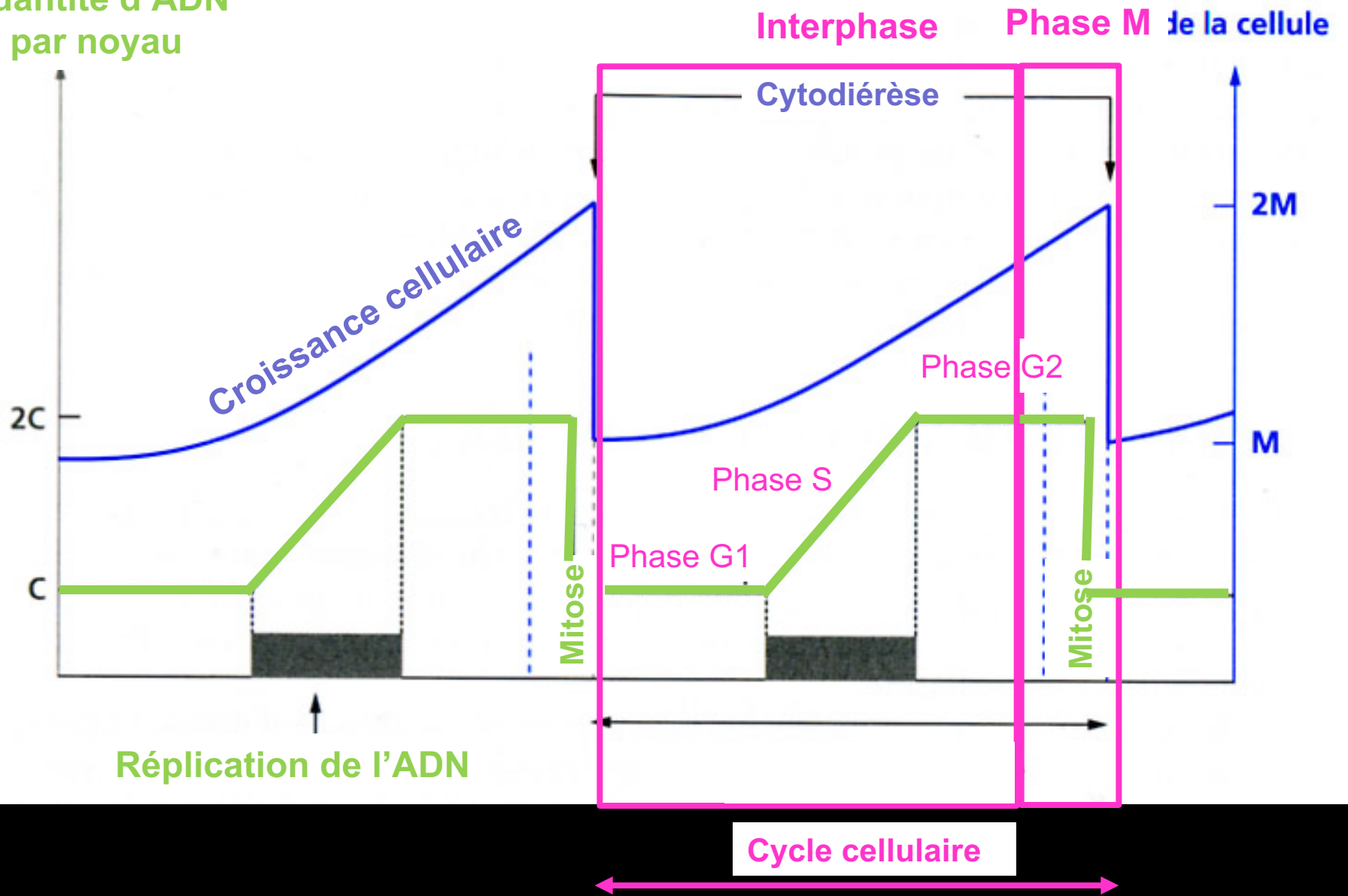

OBSERVER LES PHASES DE LA MITOSE

Légende

- Tissu de revêtement
- Tissu fondamental
- Tissu conducteur

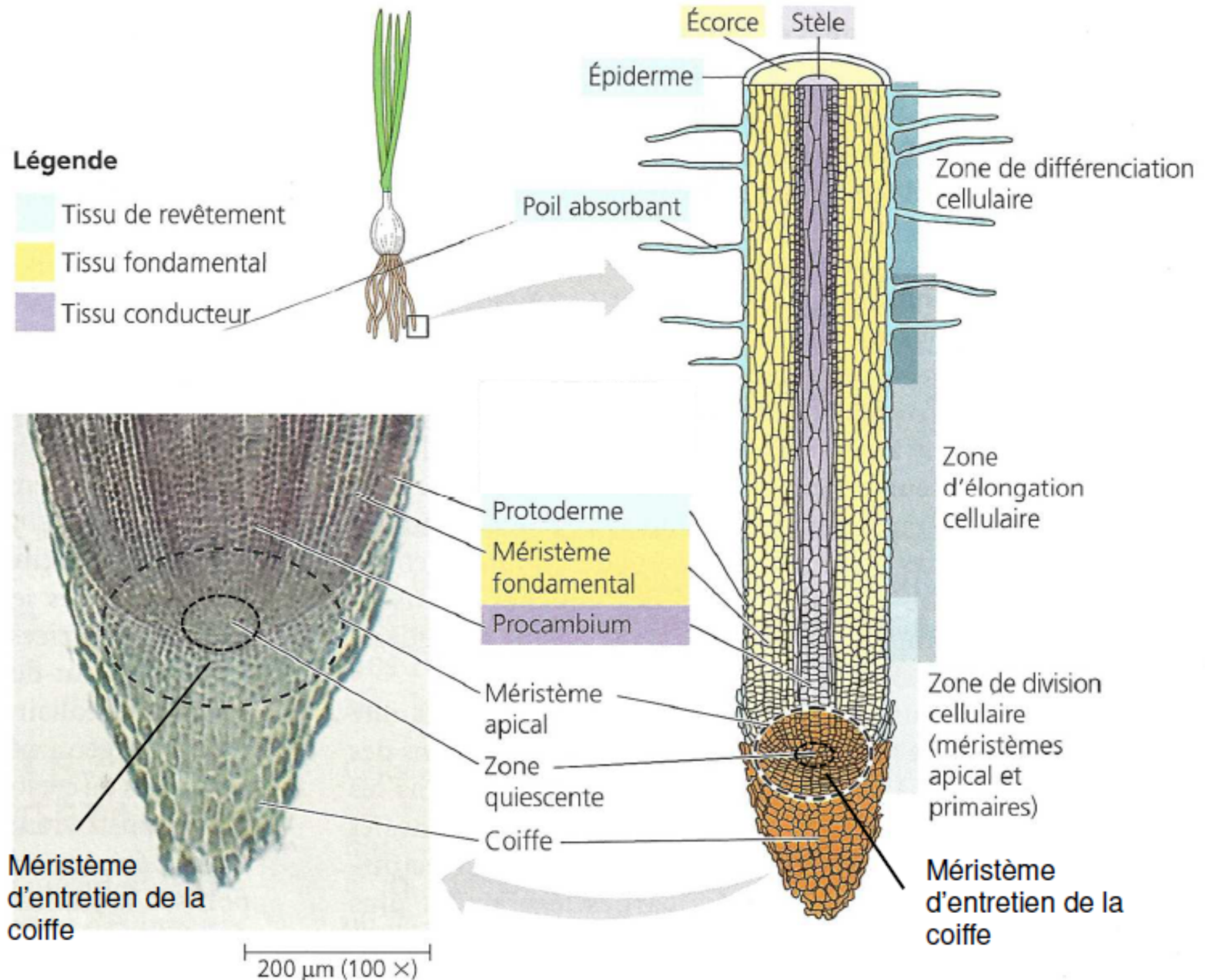



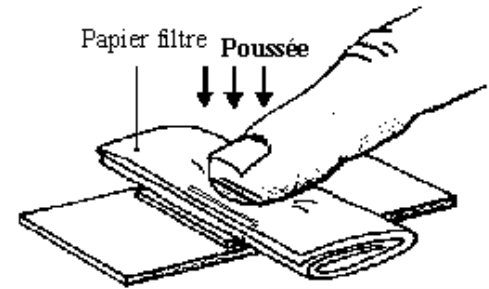
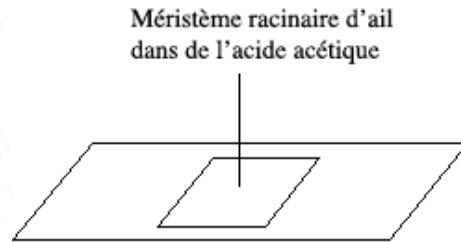
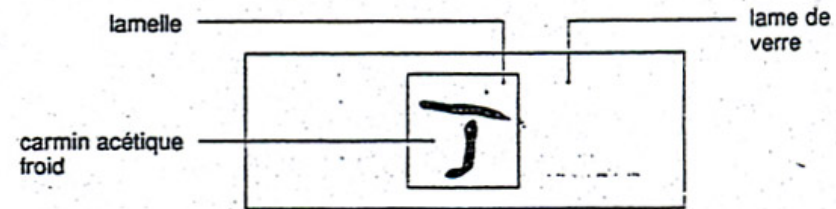
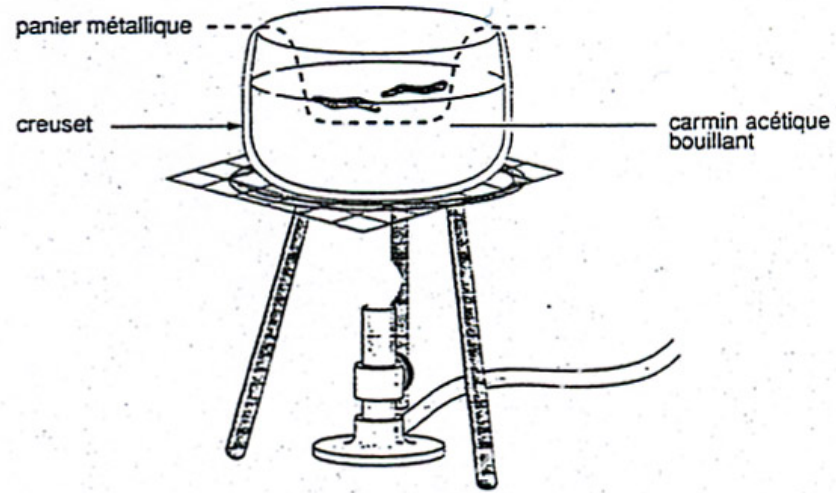
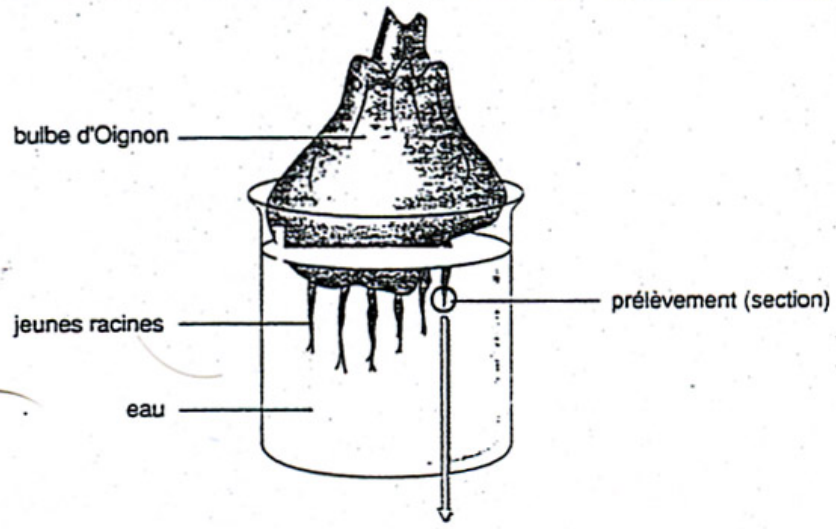

d'après georges.dolisi.free.fr



INTERPHASE



PROPHASE



METAPHASE



ANAPHASE



TELOPHASE



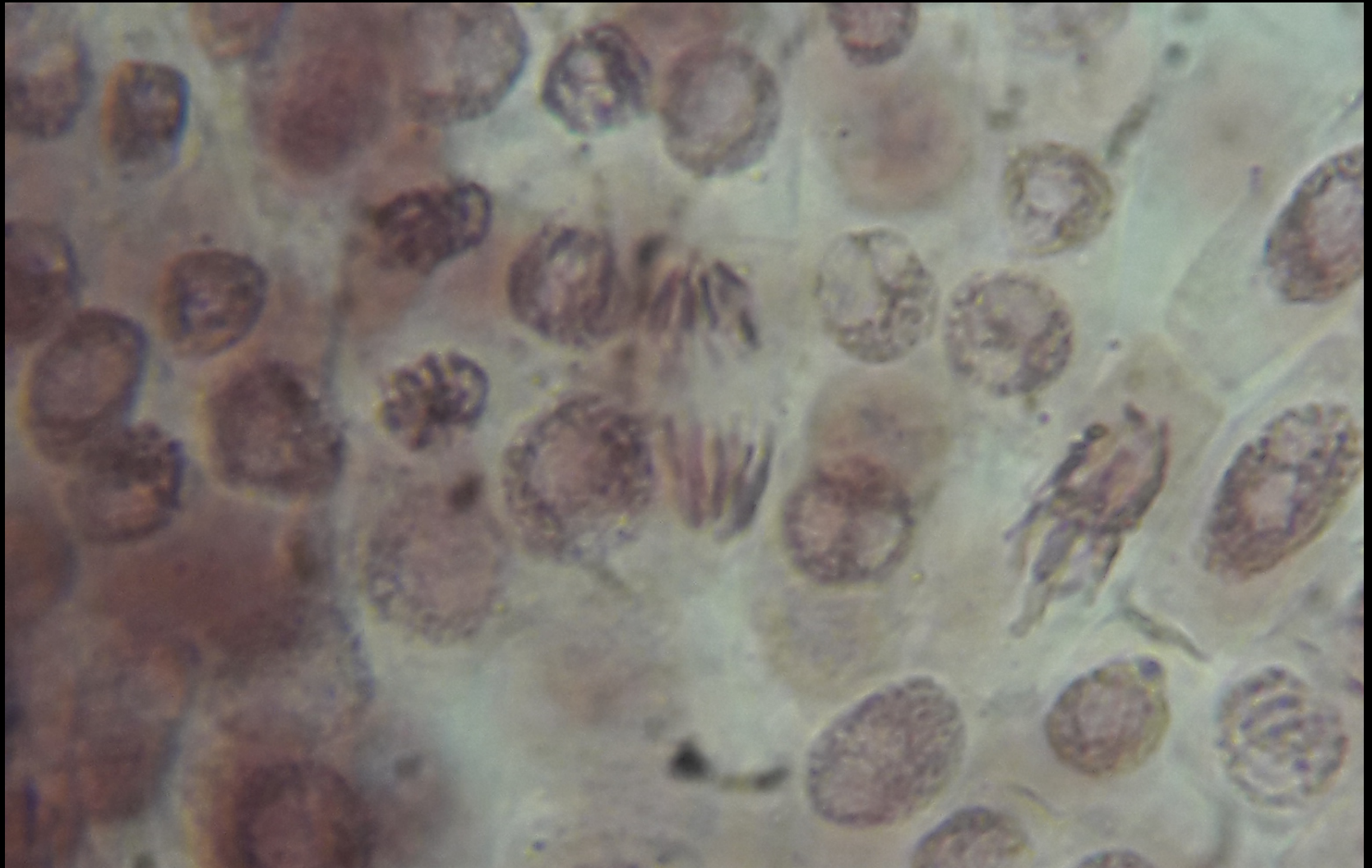

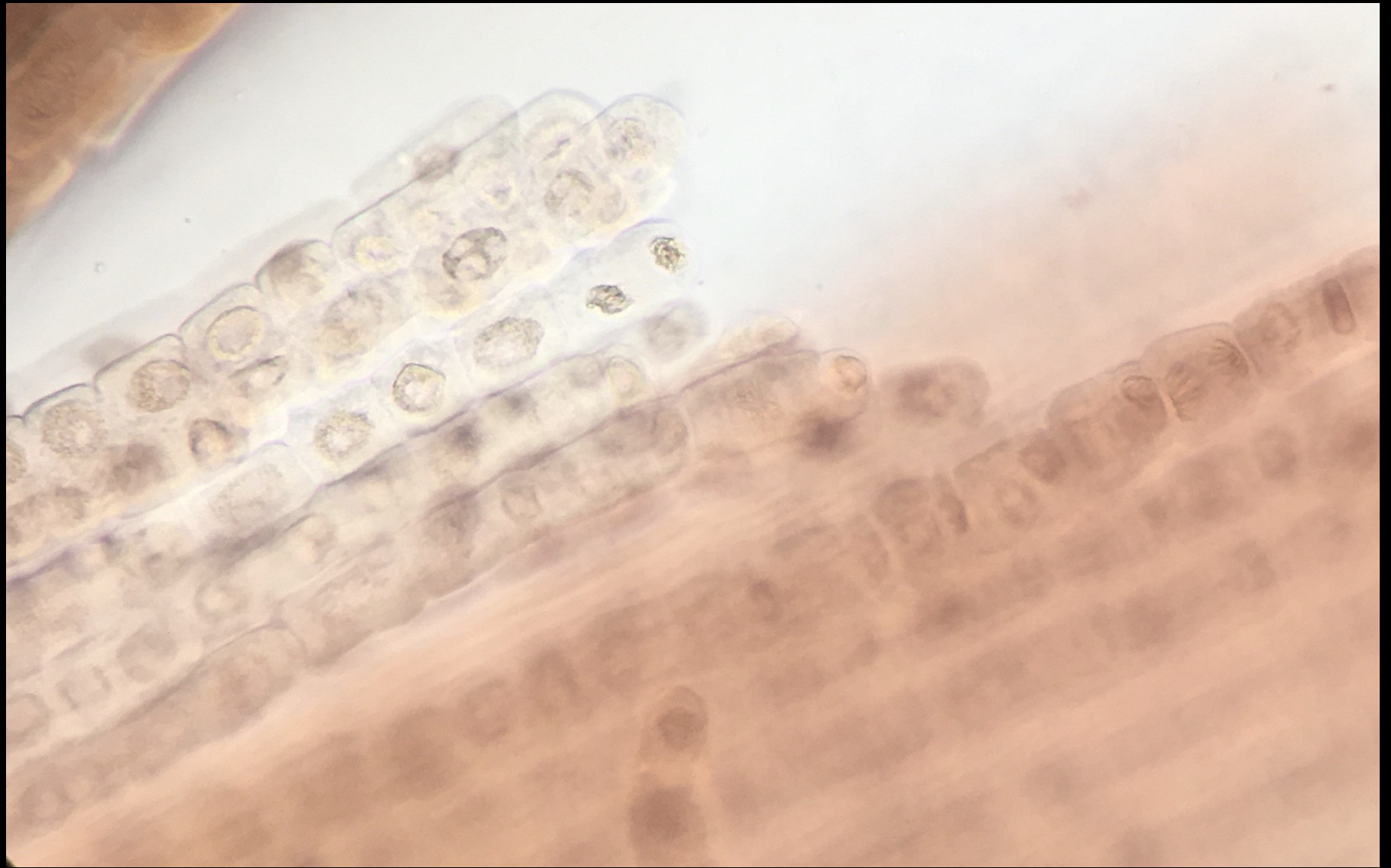

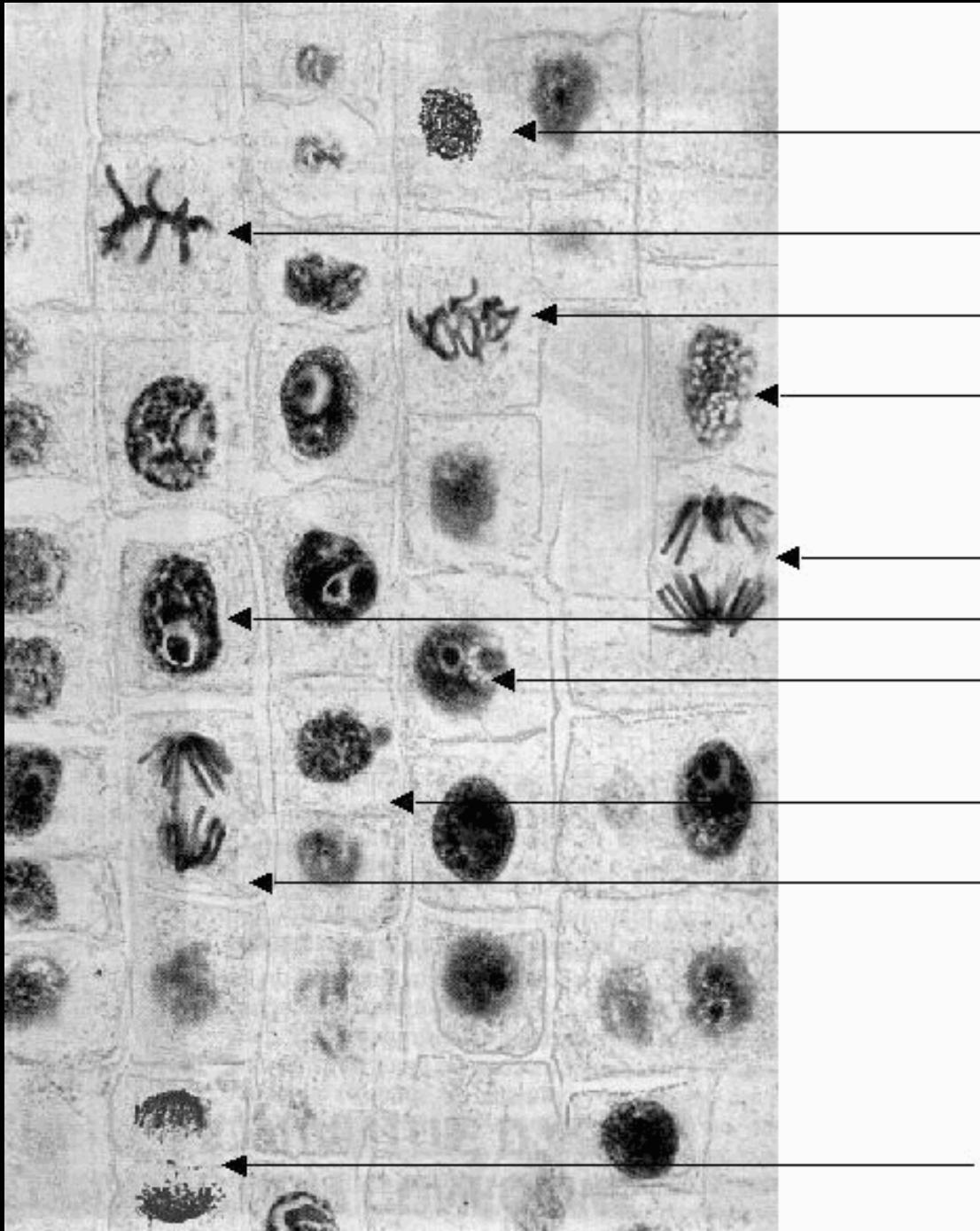

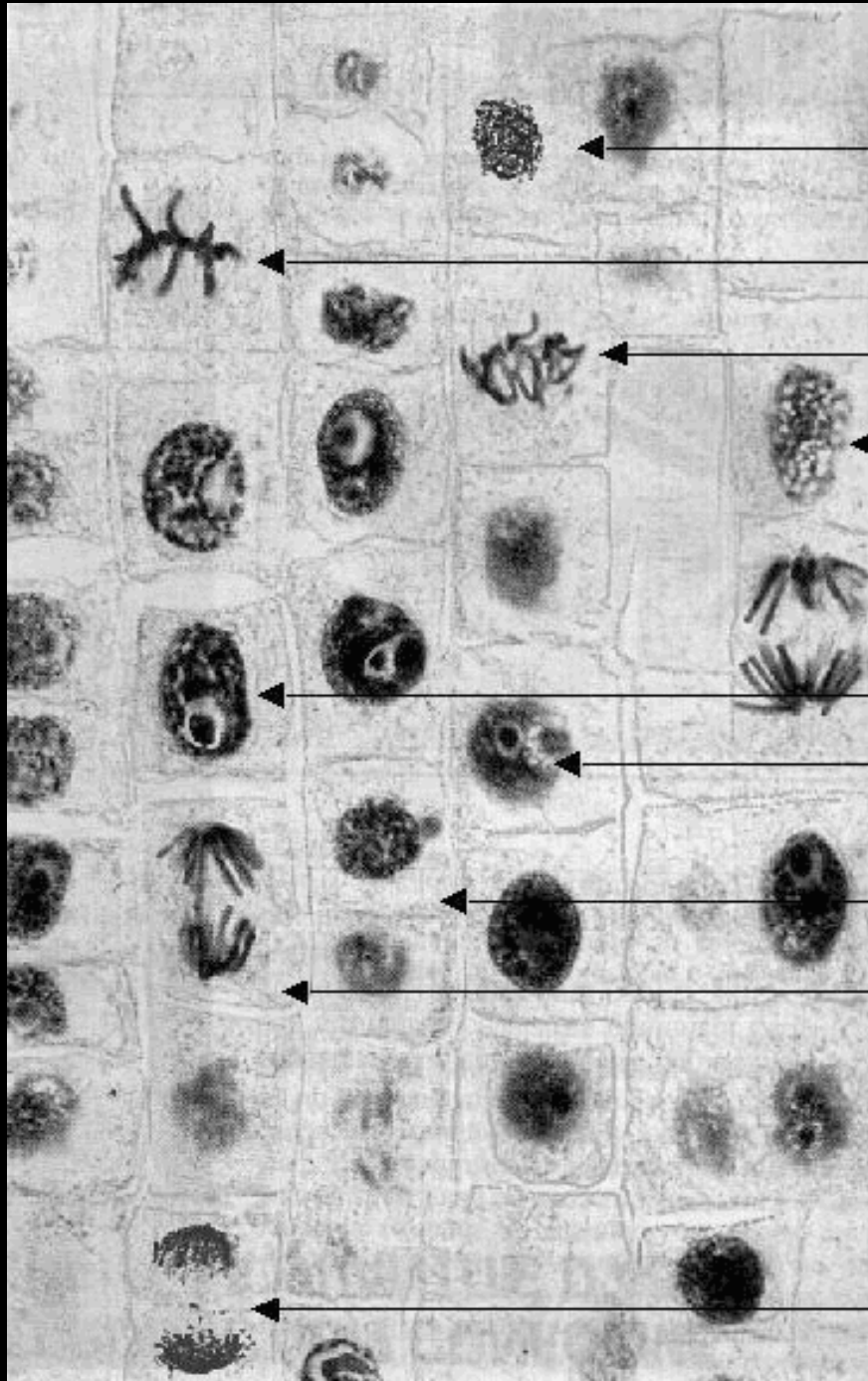

prophase

métaphase

métaphase

prophase

anaphase

interphase

début de
prophase

télophase

anaphase

cytodiérèse

(A)

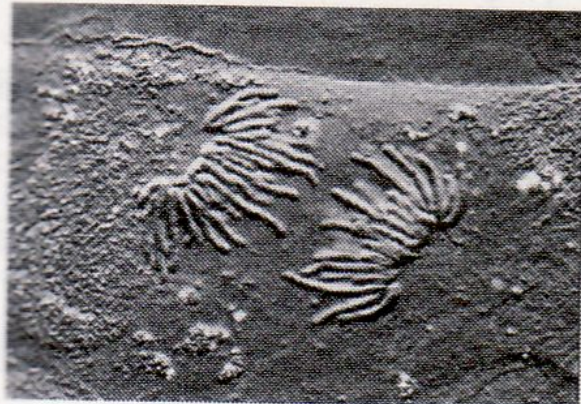

(B)

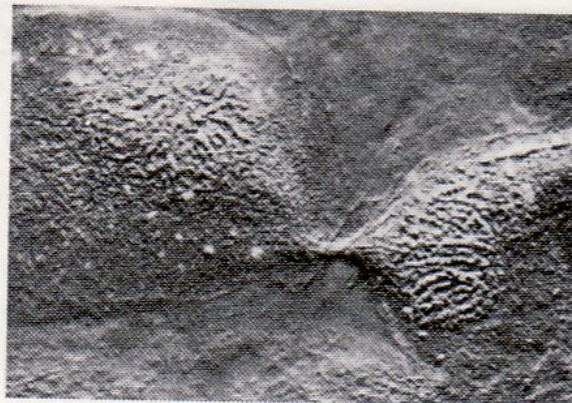

(C)

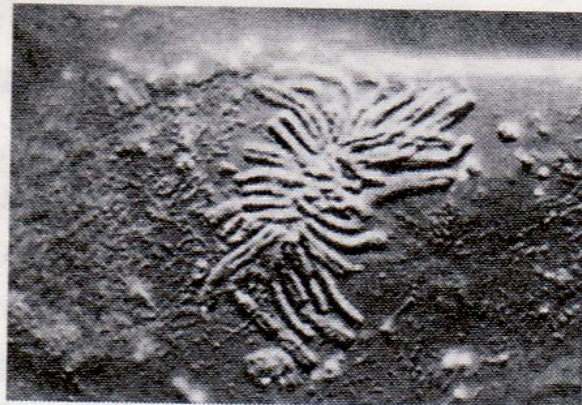

(D)



(E)



(F)



Cycle cellulaire

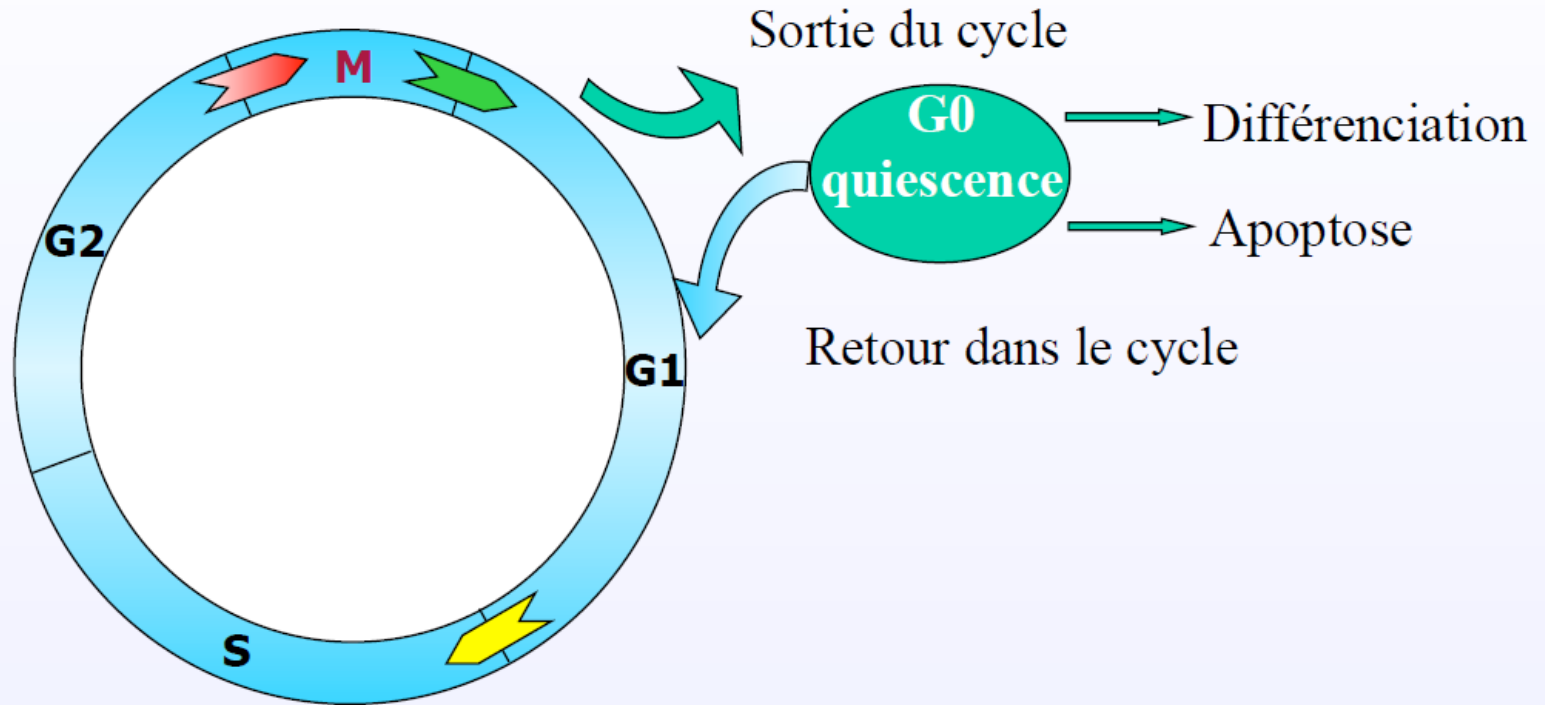

Représentation schématique d'un cytomètre de flux

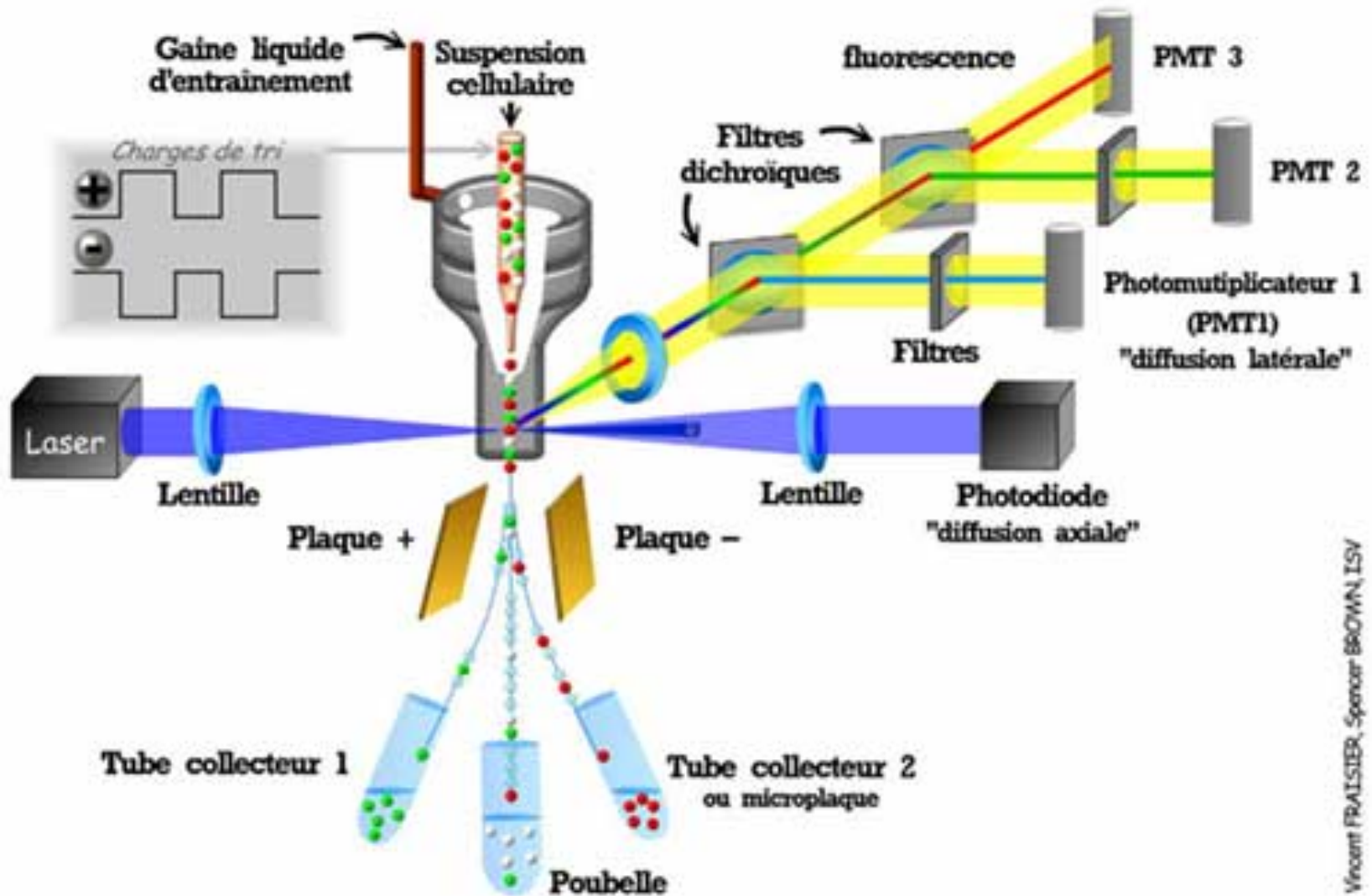

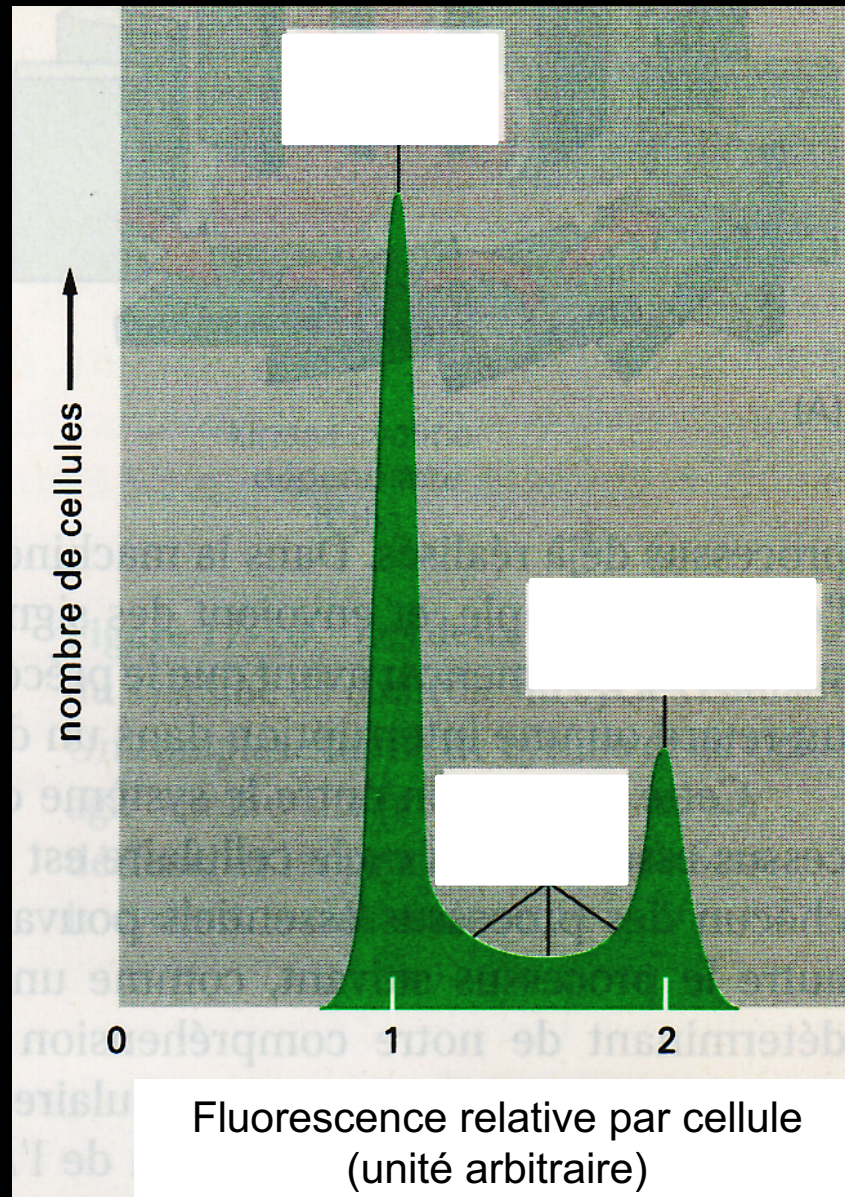

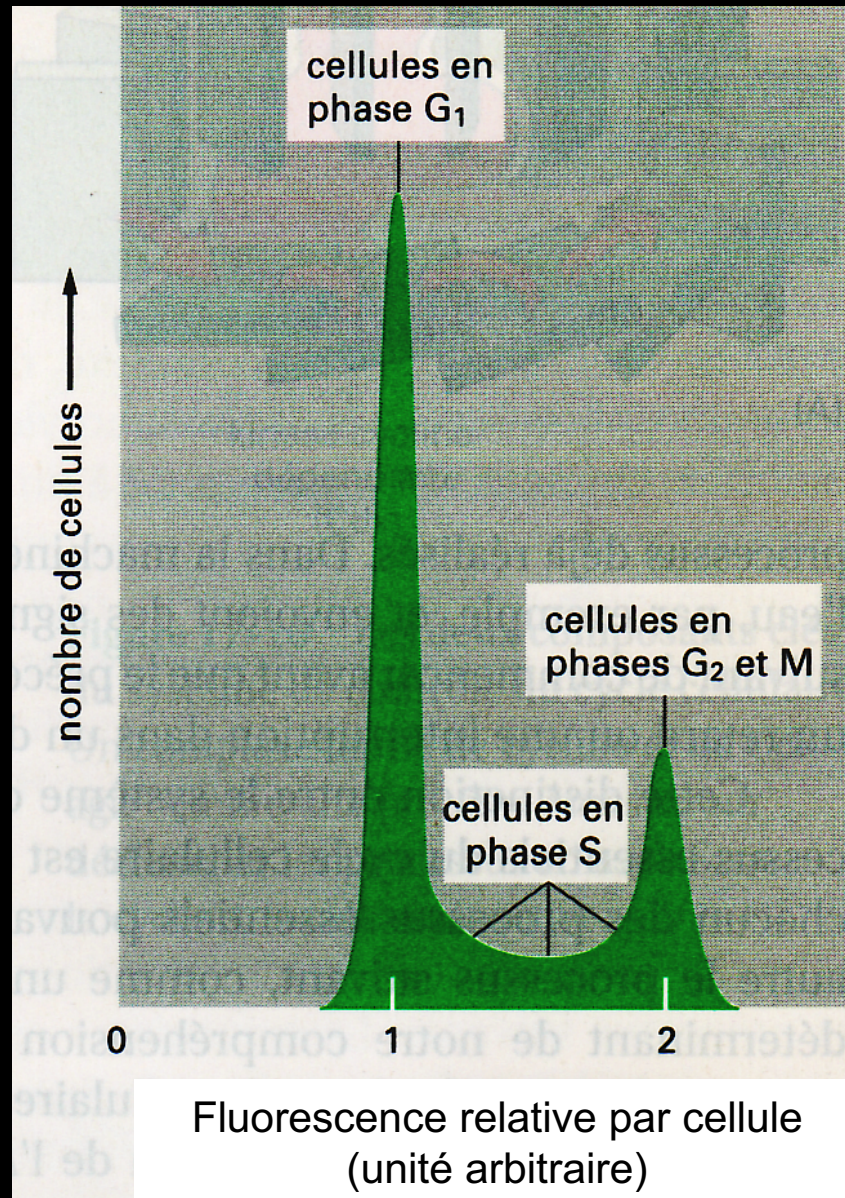

OBSERVER LES PHASES DE LA MEIOSE

Rappel sur la méiose

Correction : Schéma bilan des étapes de la méiose pour une cellule à $2n=4$

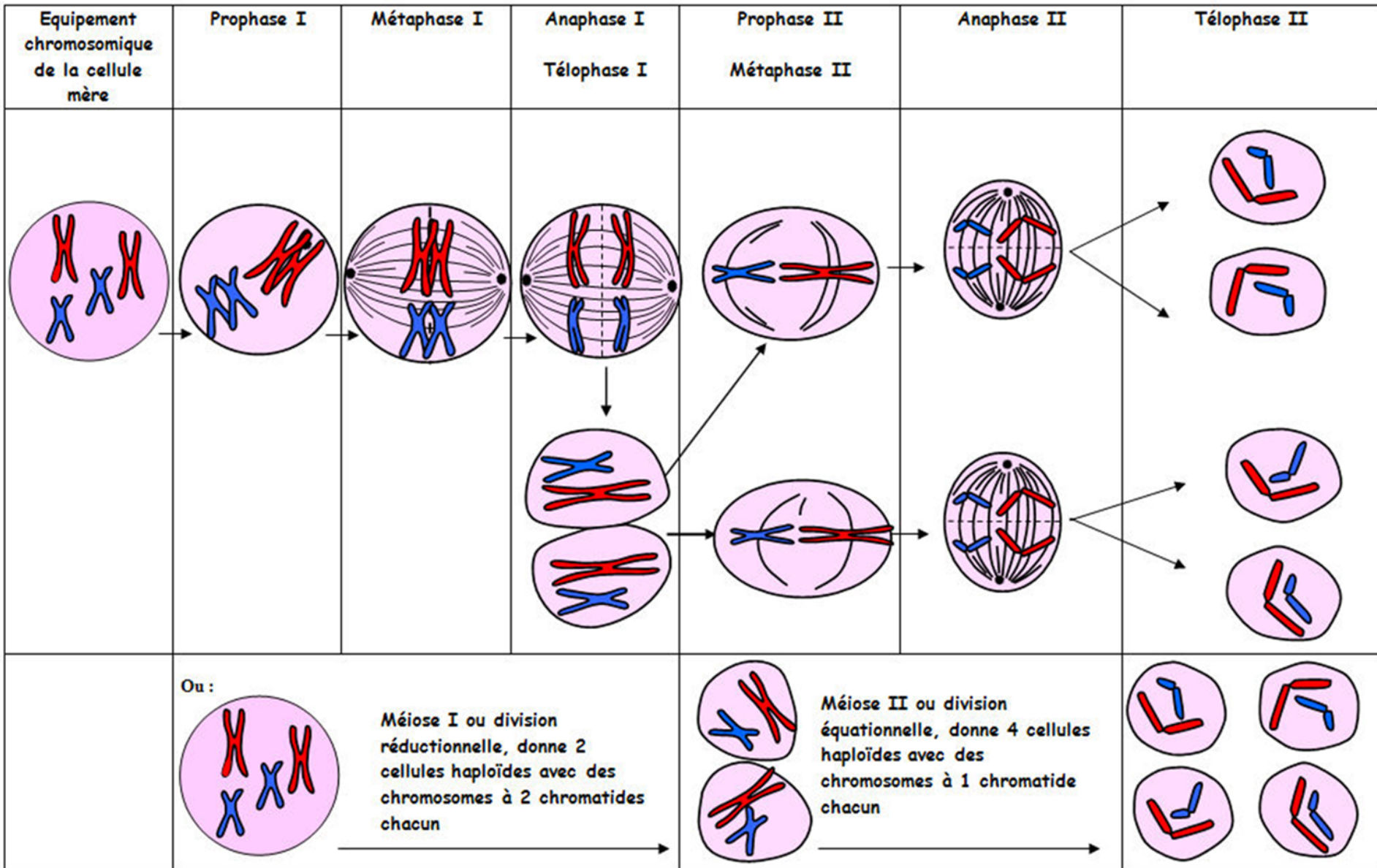

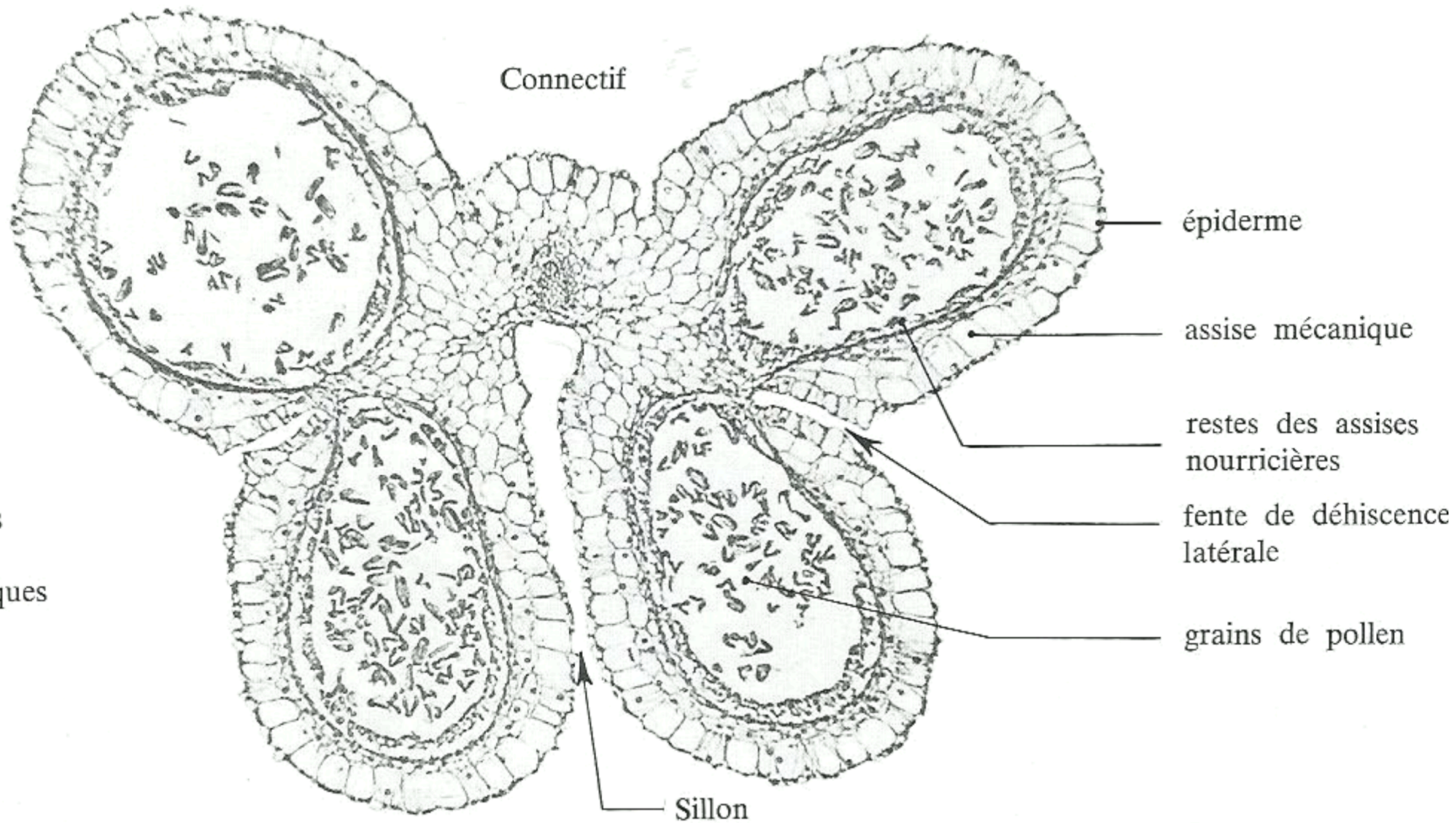

Anthère mûre. Coupe transversale. Lis ($\times 20$).

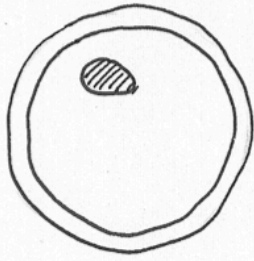

cellule mère des
microspores

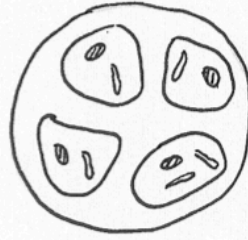

une tétrade de
microspores

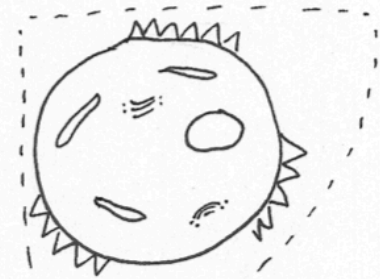

une tétraspore en
maturation

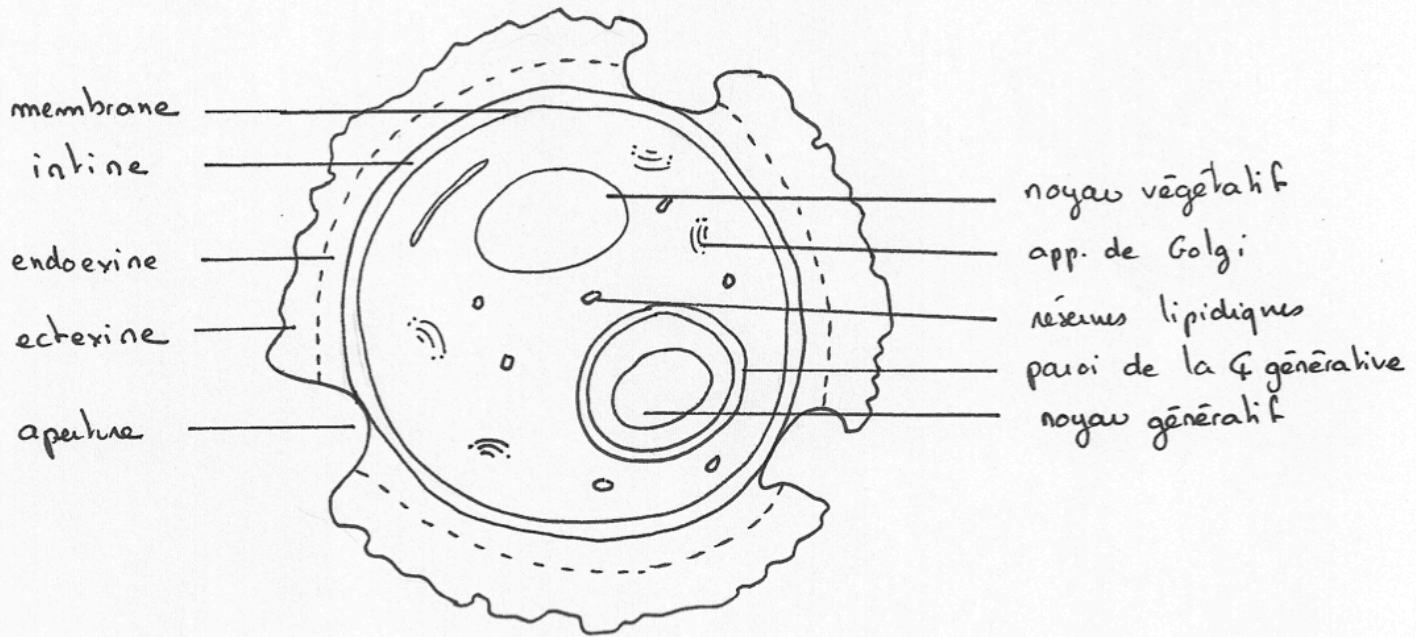

un grain de pollen

Méiose dans les anthères de fleurs d'Angiospermes

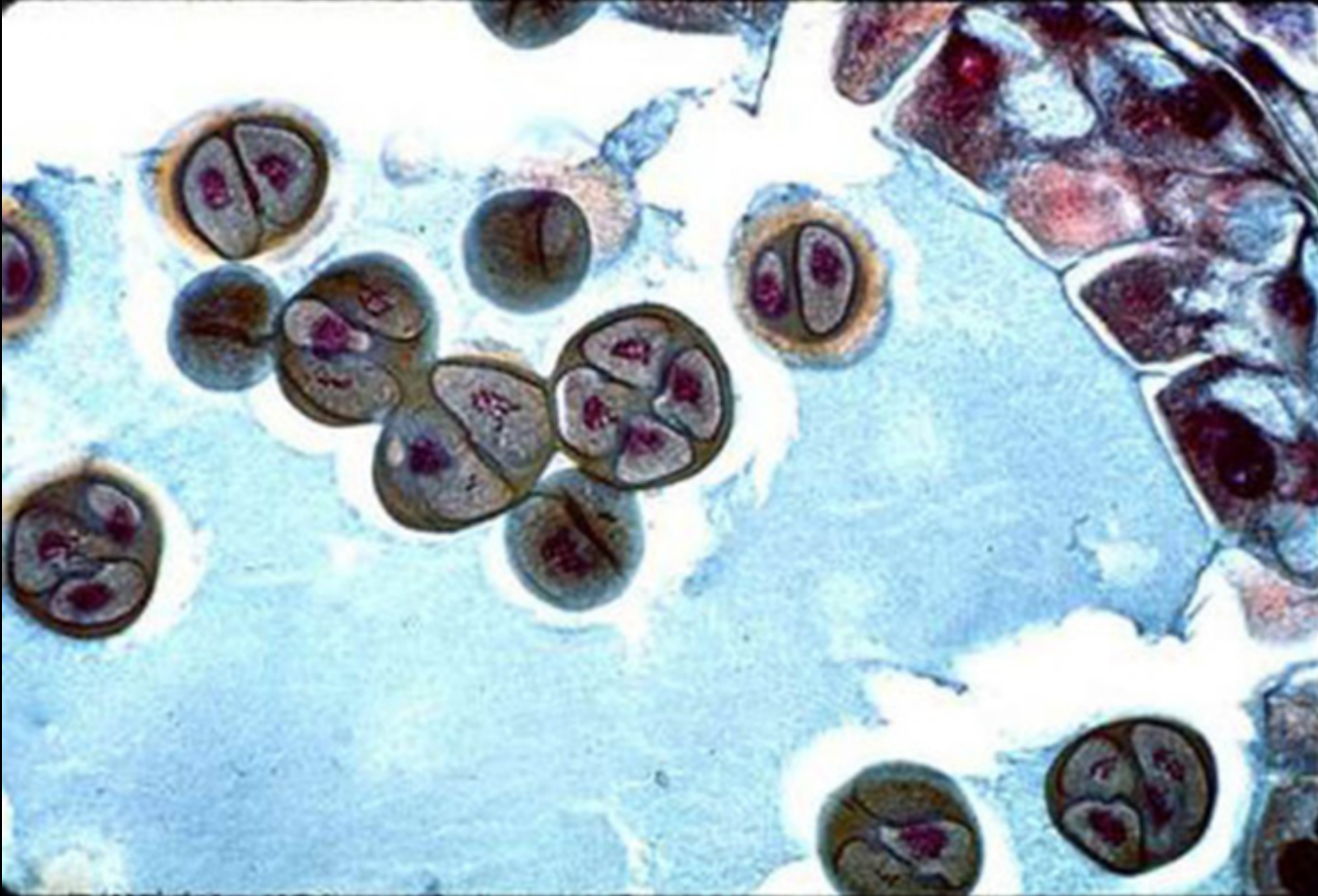

Fin de méiose II : observation de tétrades de spores

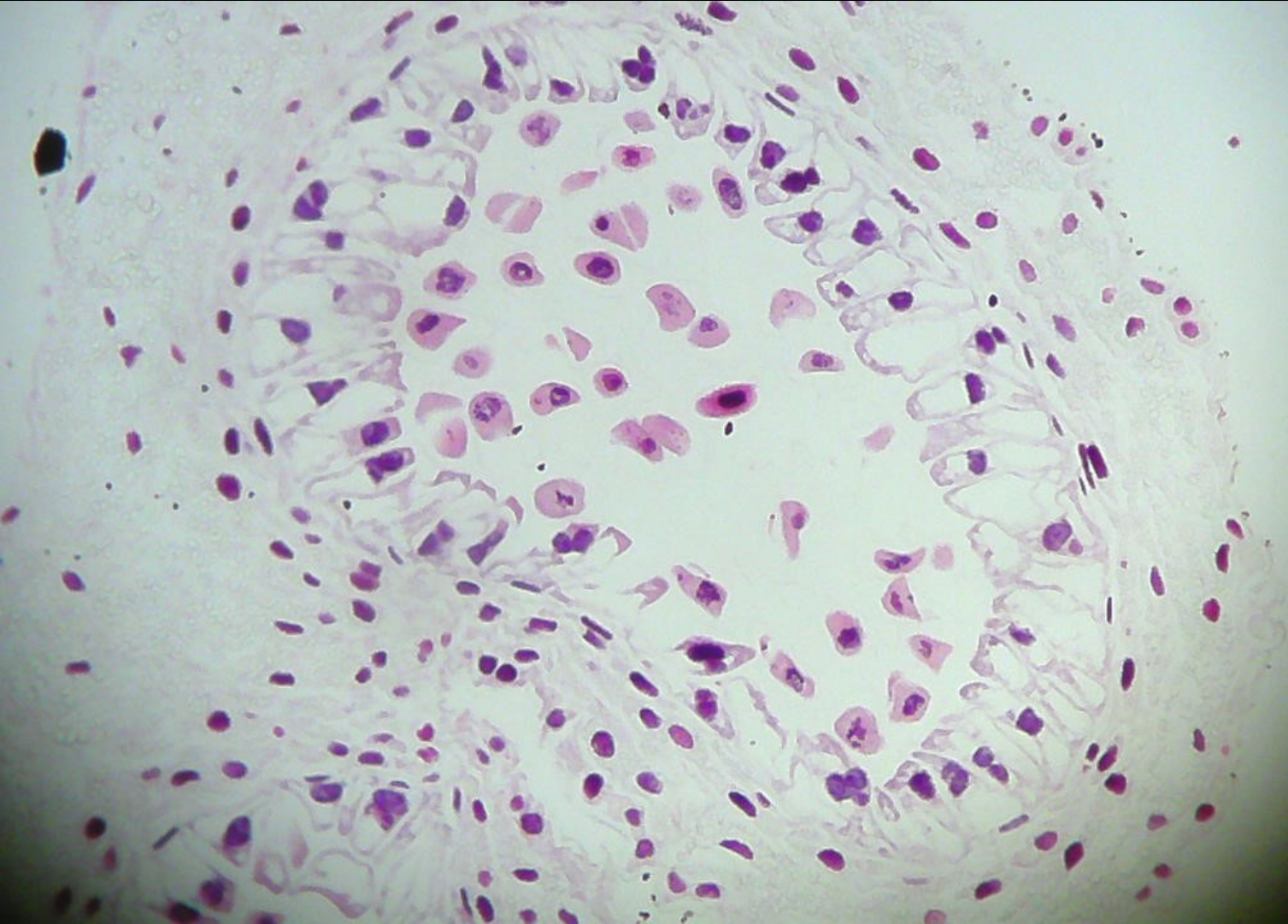

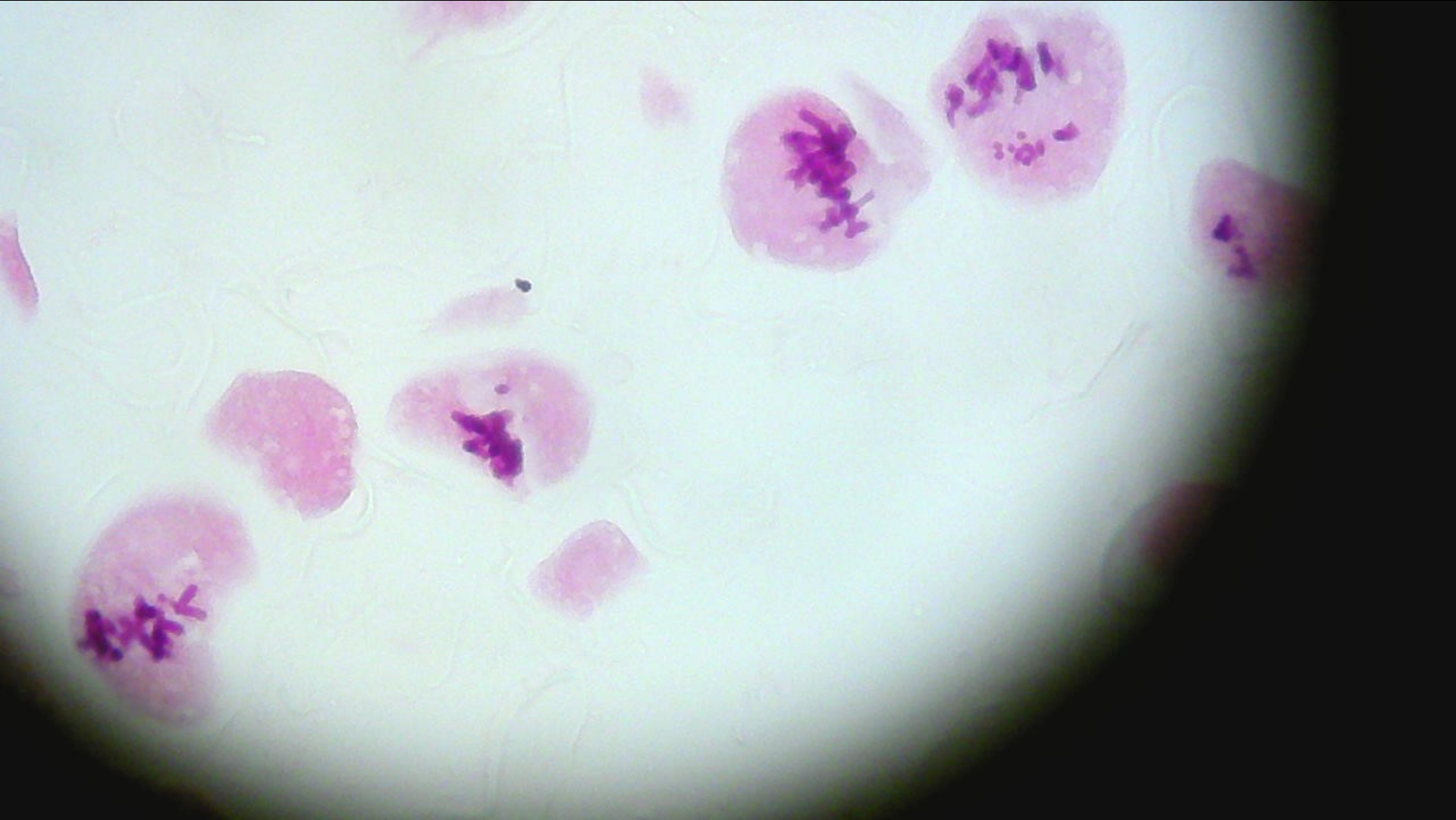

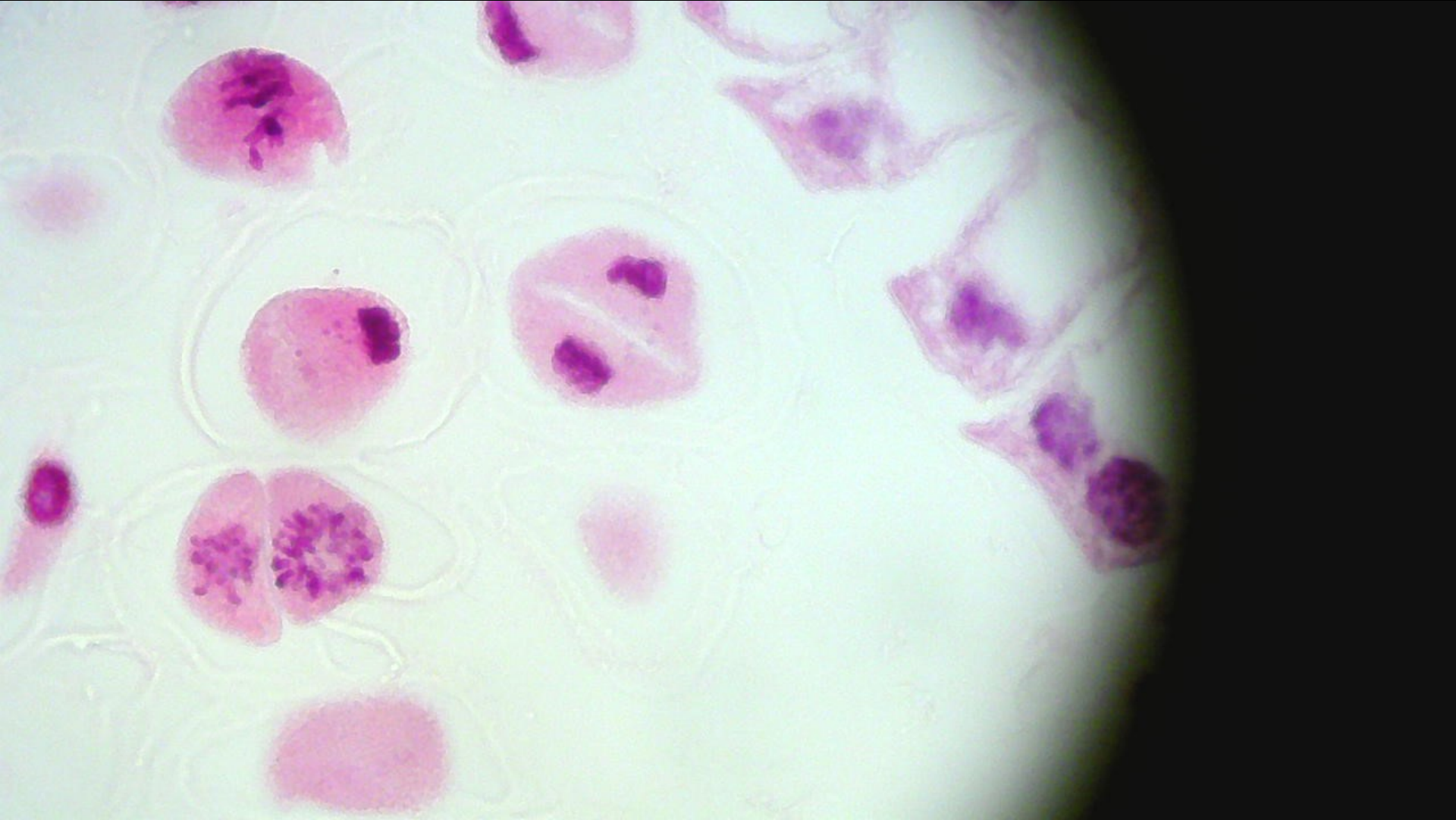

1

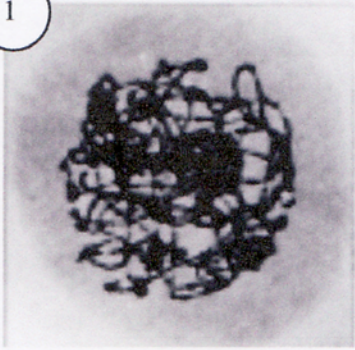

2



3

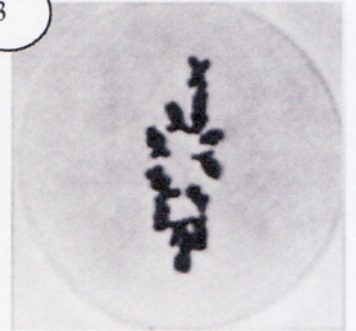

4

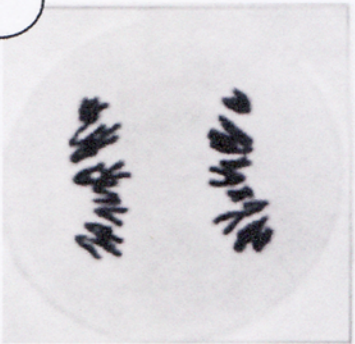

5

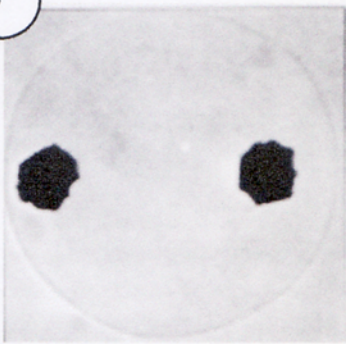

6



7

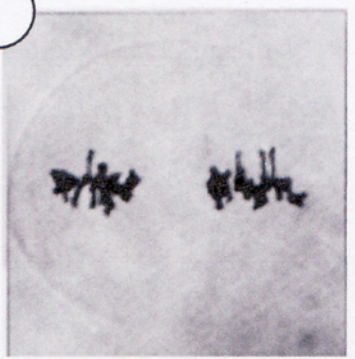

8

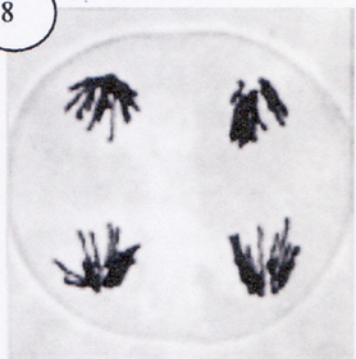

9



Diagramme de variation de la quantité d'ADN



Correction : Schéma bilan des étapes de la méiose pour une cellule à $2n=4$

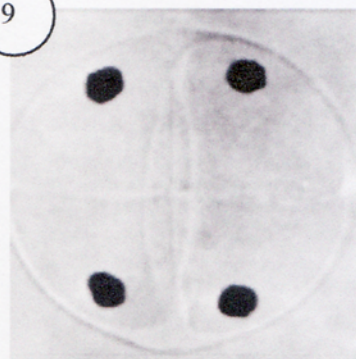
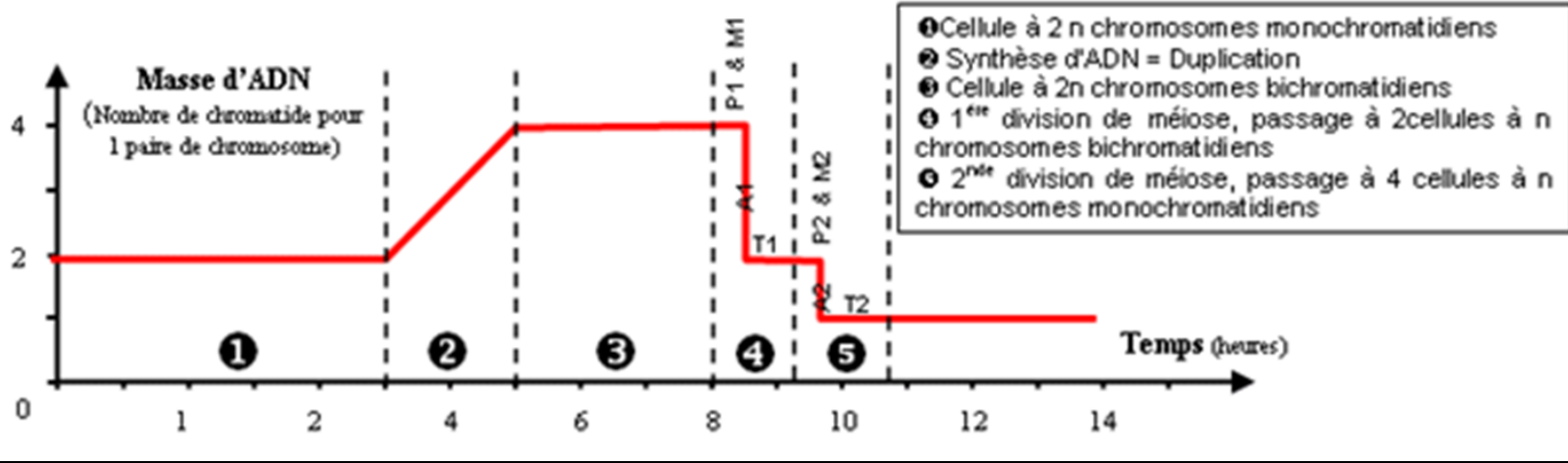
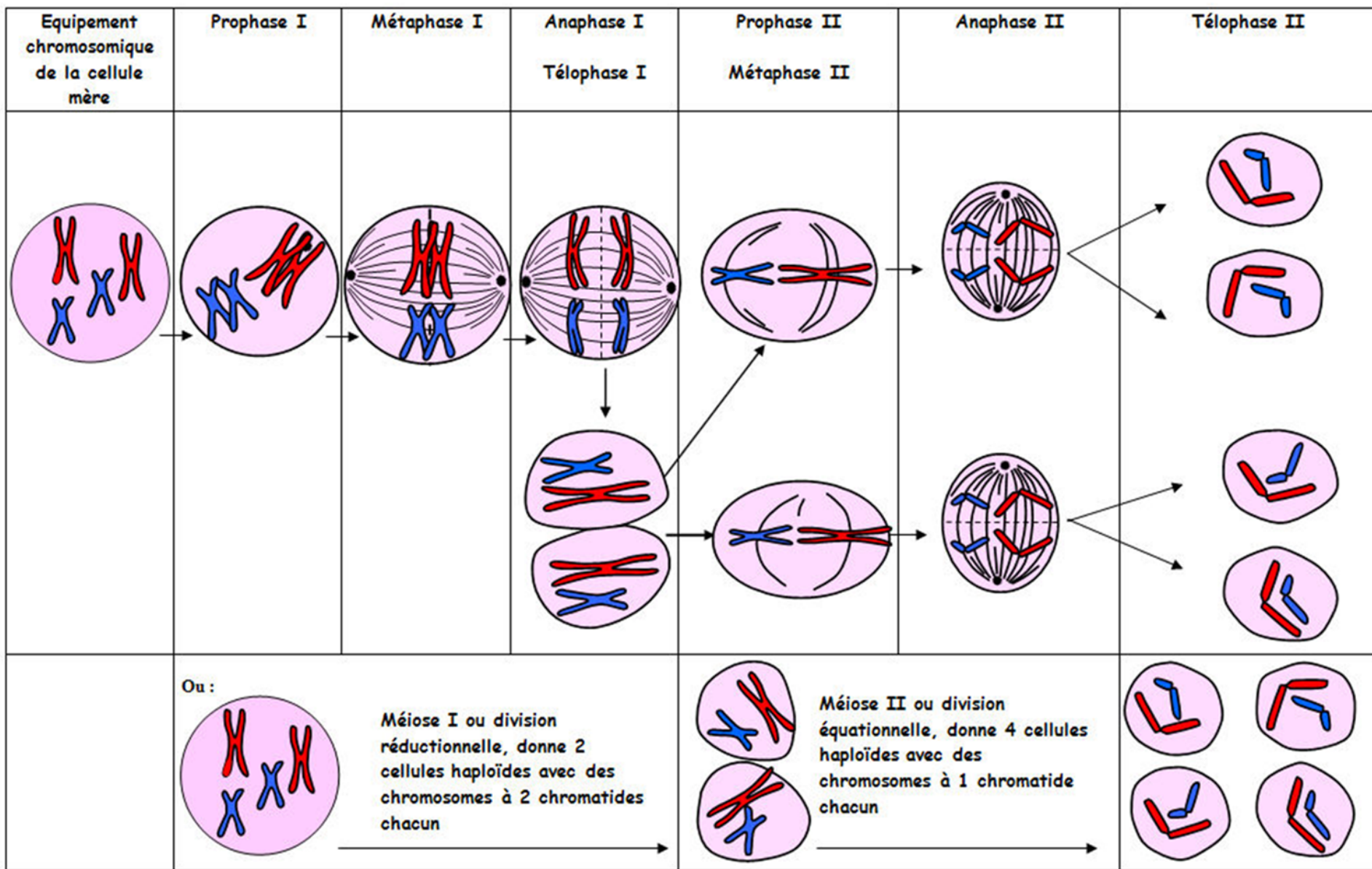

**CARACTERISTIQUES CELLULAIRES
DES DIVISIONS CELLULAIRES :
Organisation du chromosome
métaphasique**

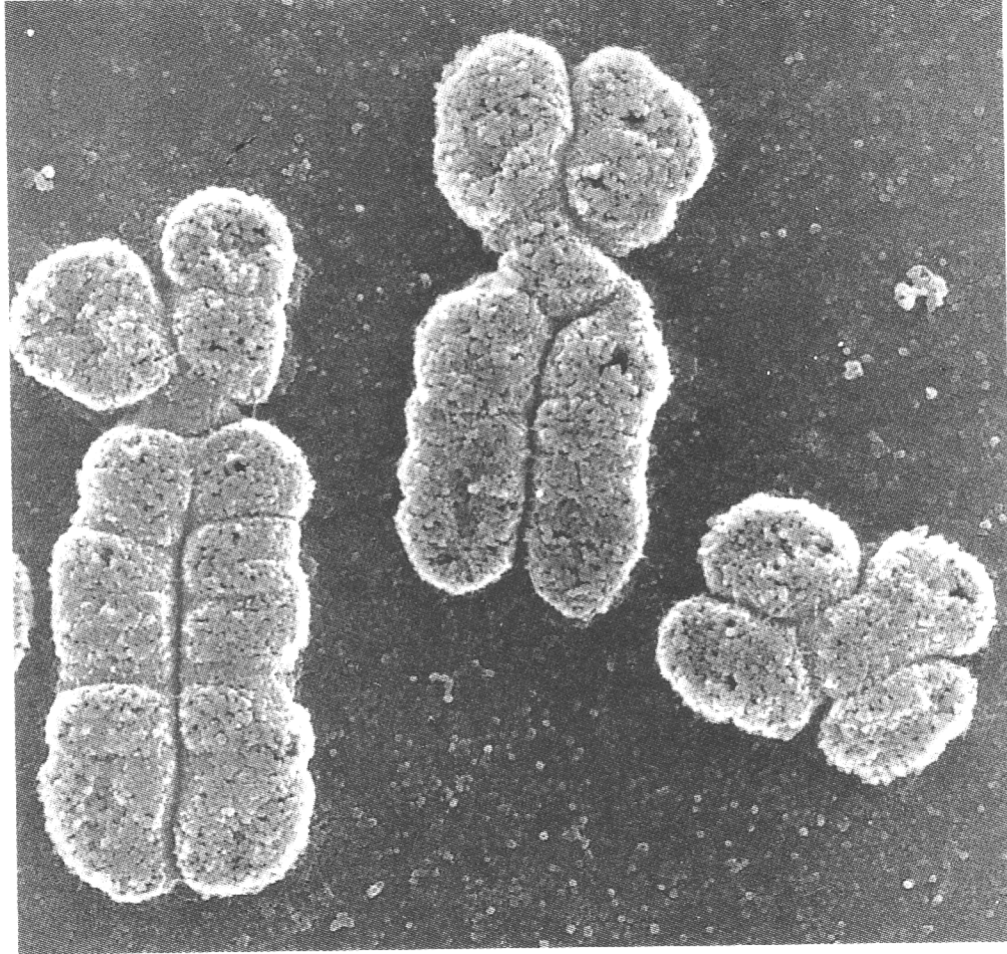

1 μ m

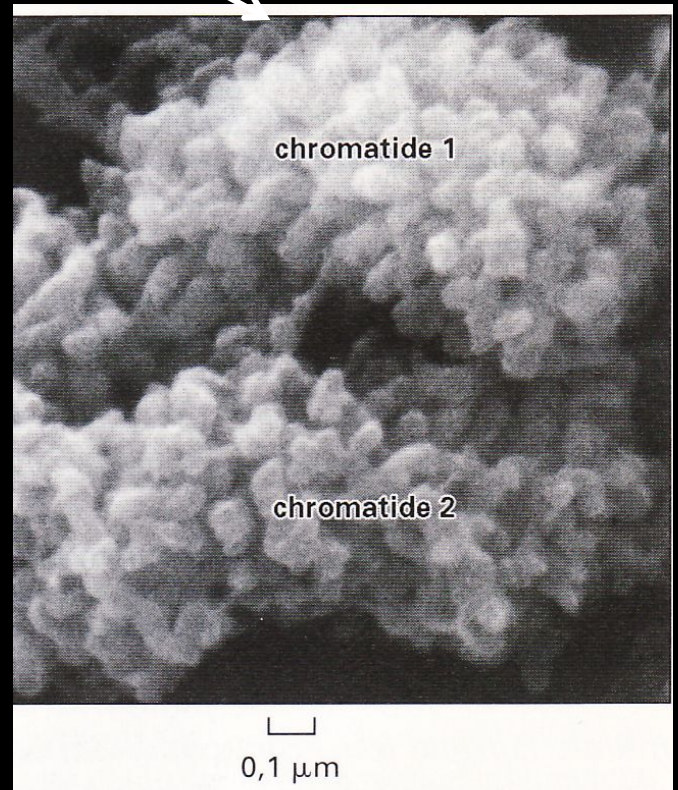
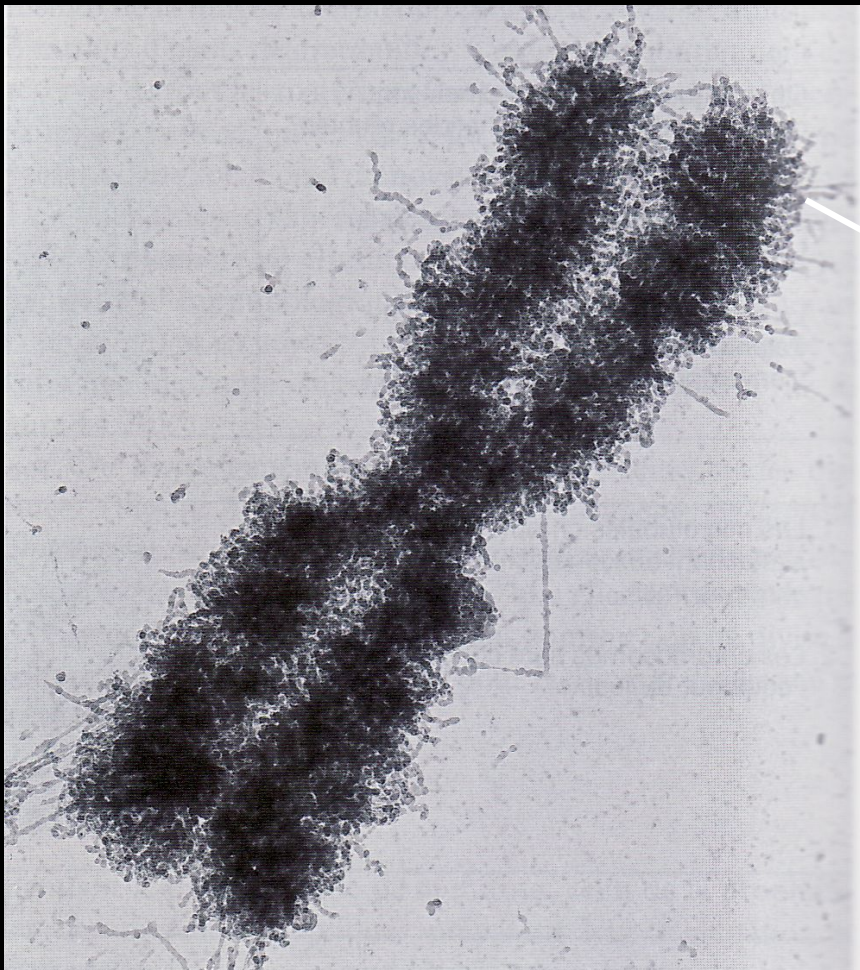

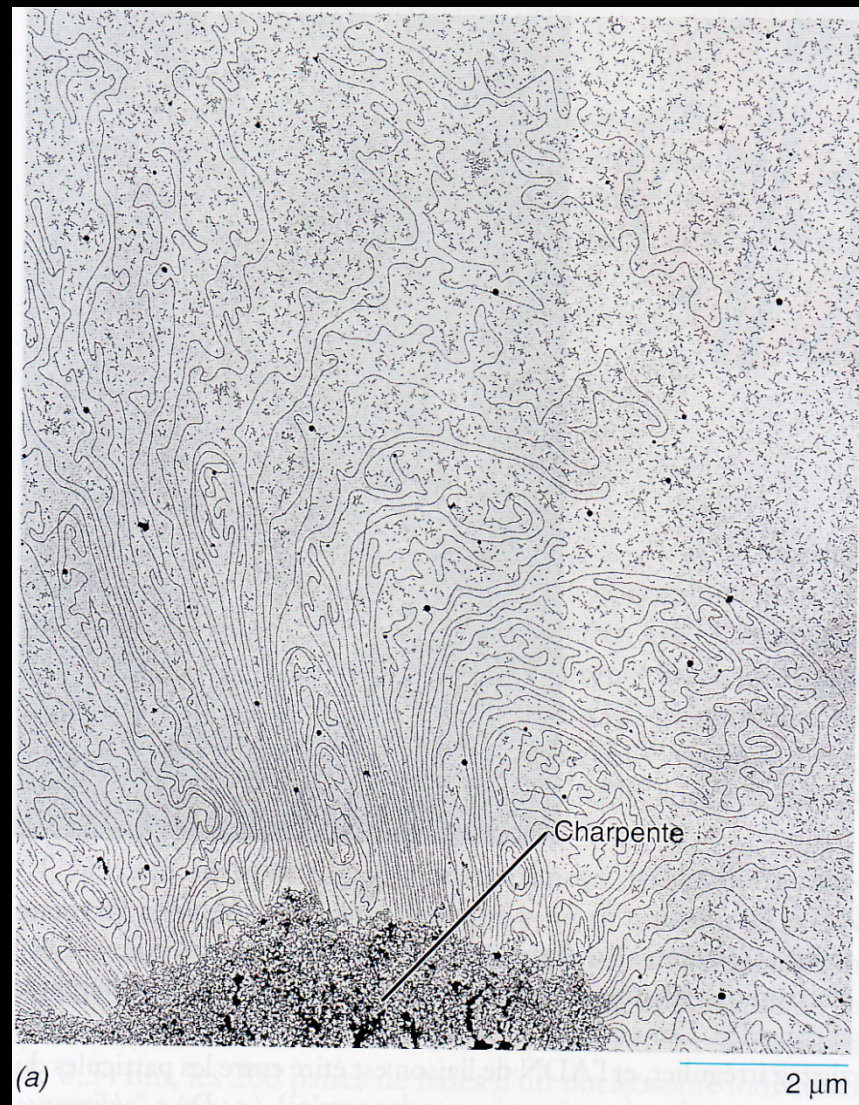
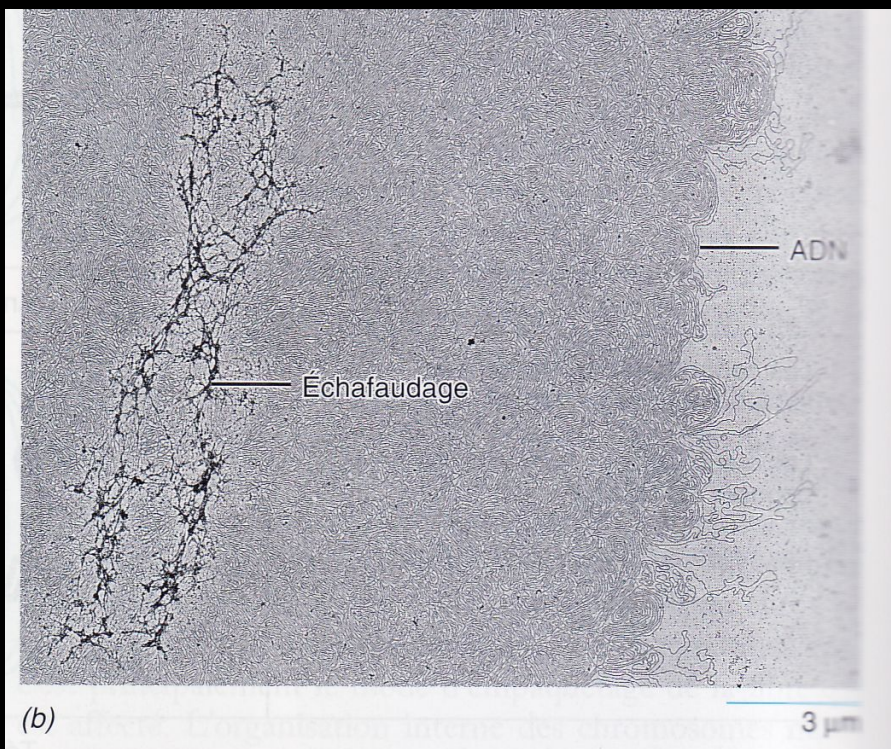

Technique d'immunomarquage

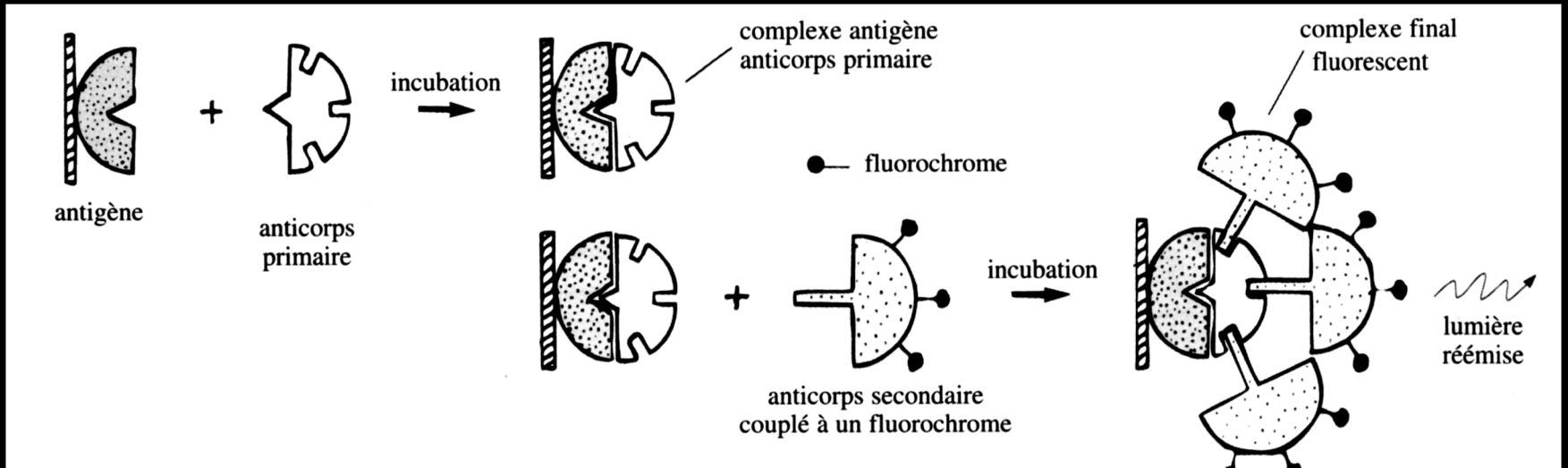

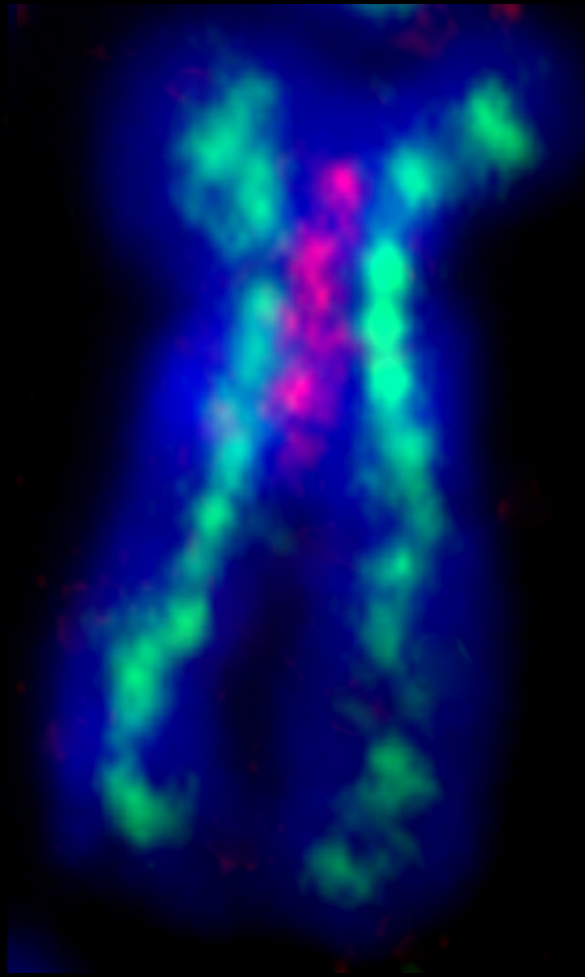
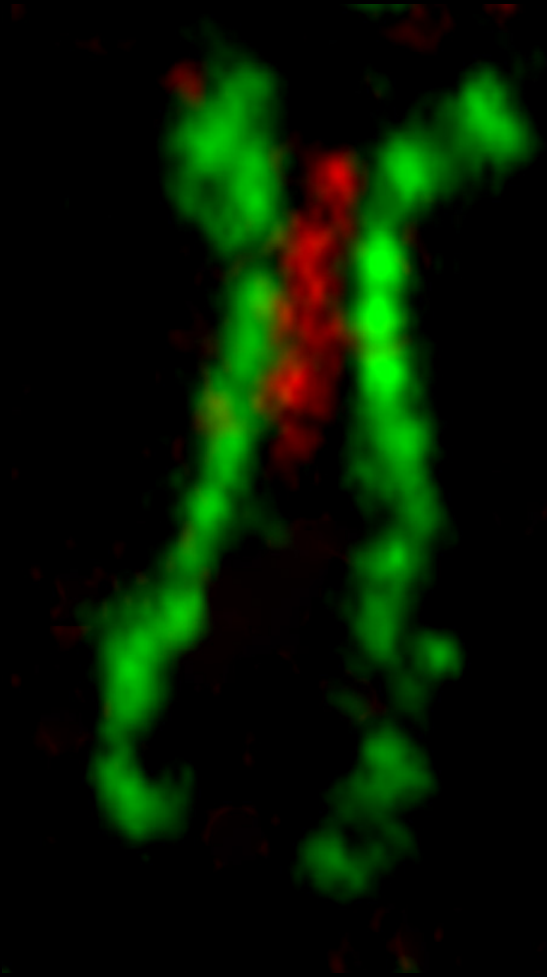

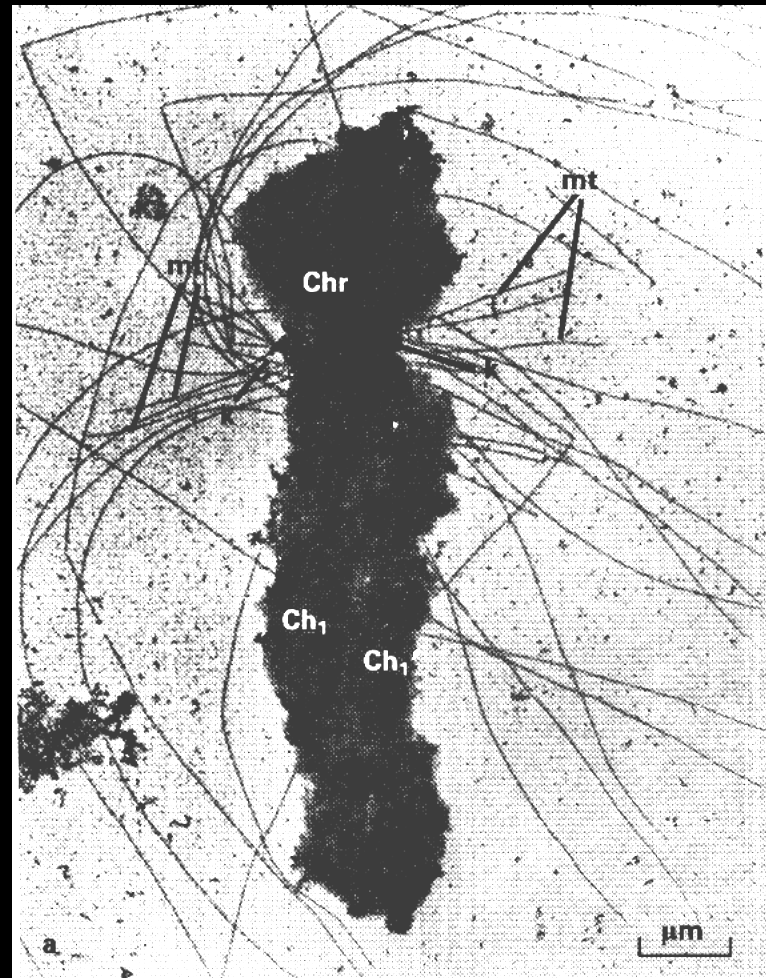
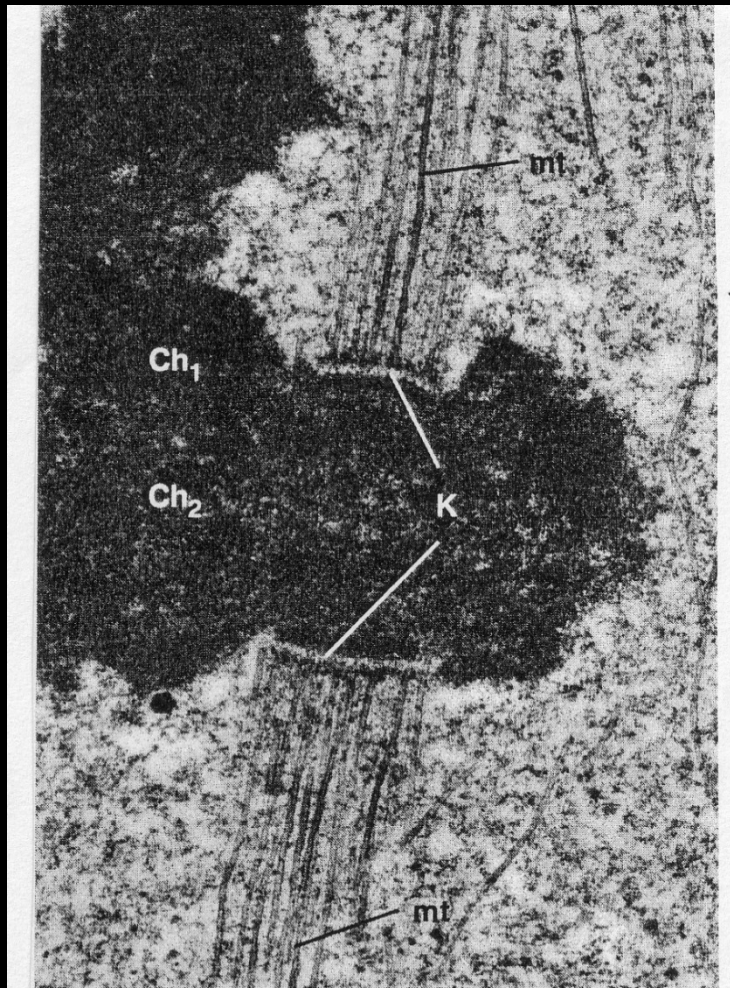

Organisation d'un chromosome métaphasique.

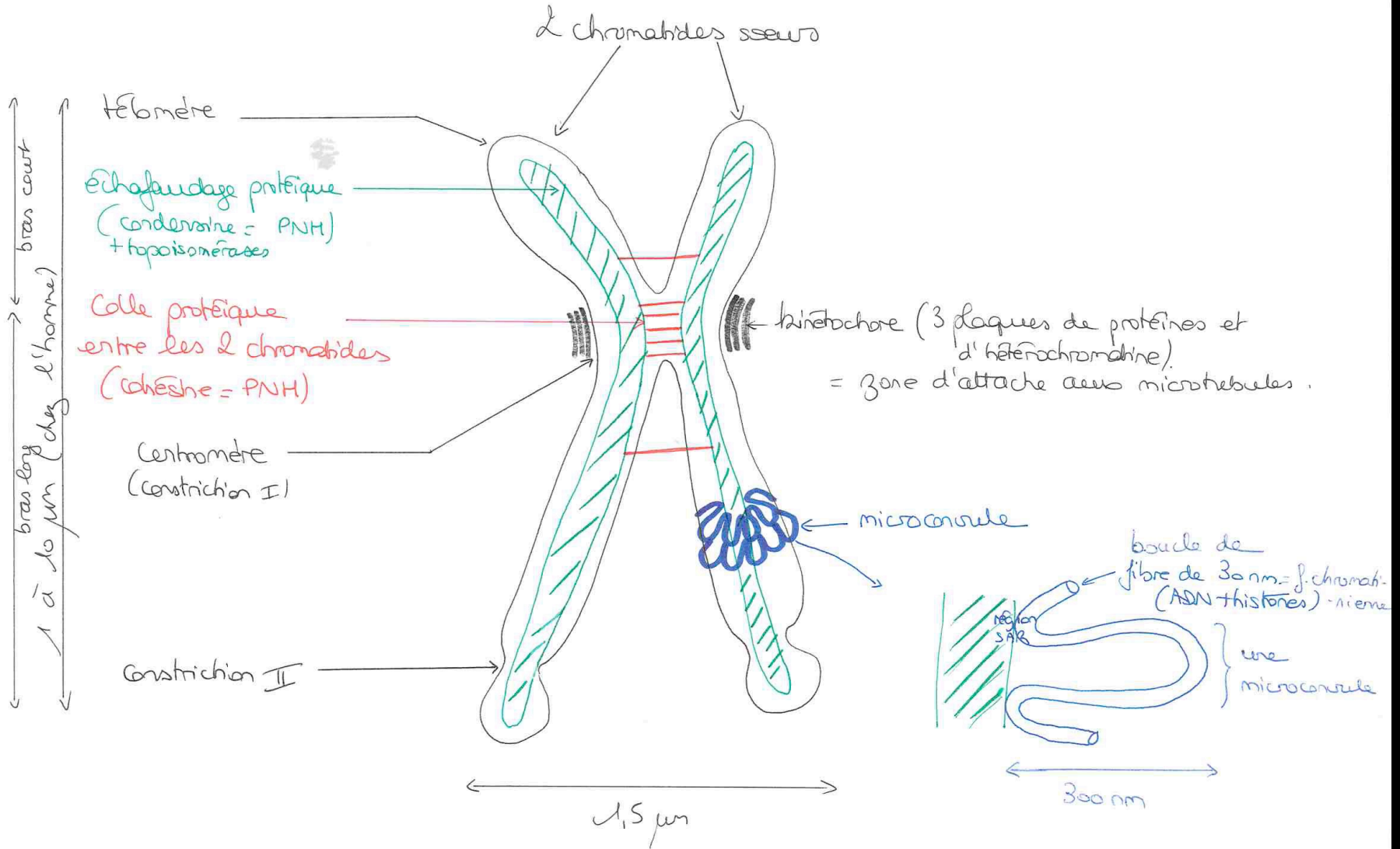

**CARACTERISTIQUES CELLULAIRES
DES DIVISIONS CELLULAIRES :
Organisation et dynamique du fuseau de
division**

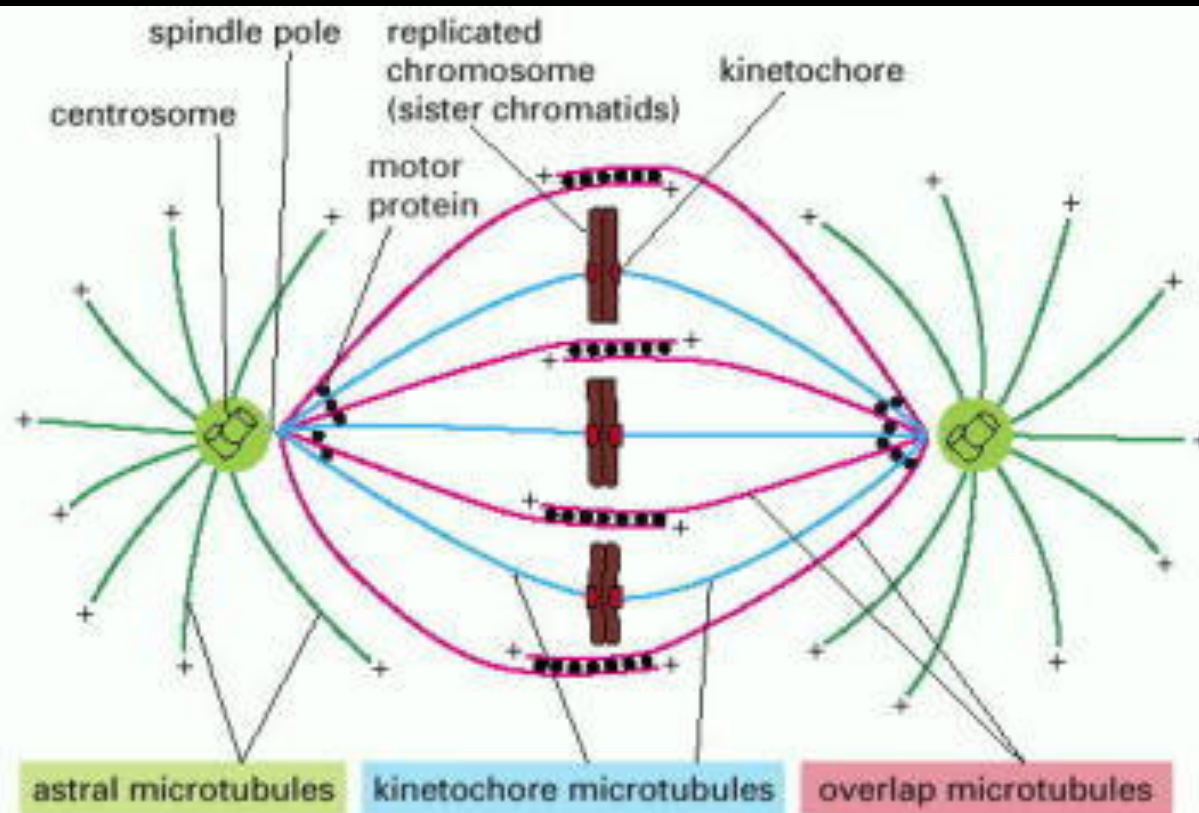

(A)

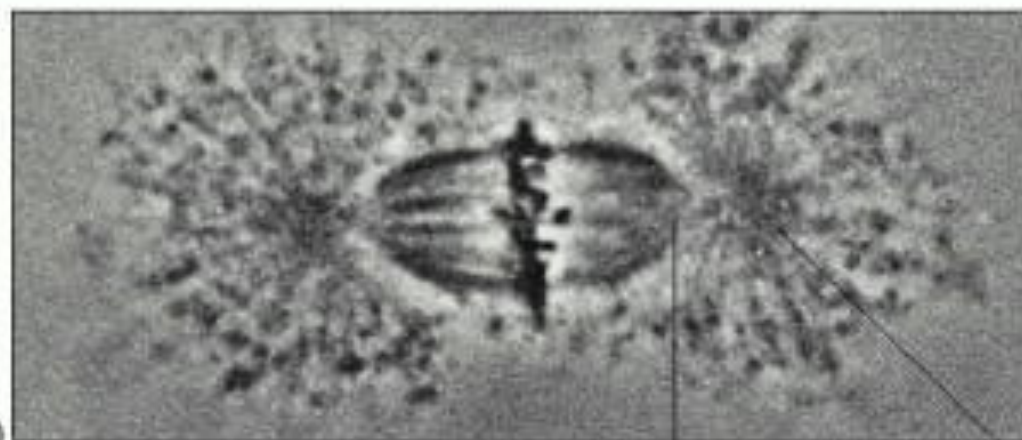

(B)

10 μm

spindle pole

centrosome

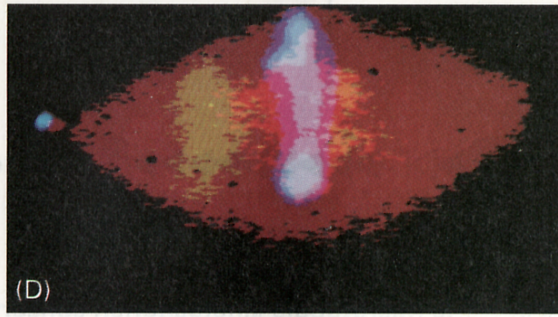
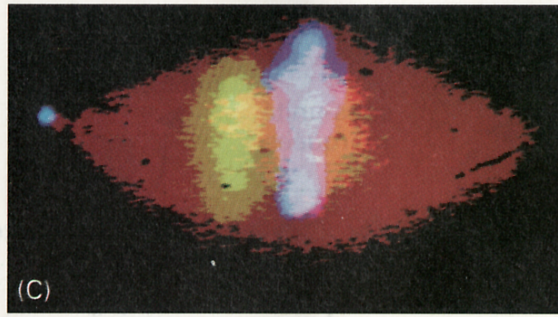
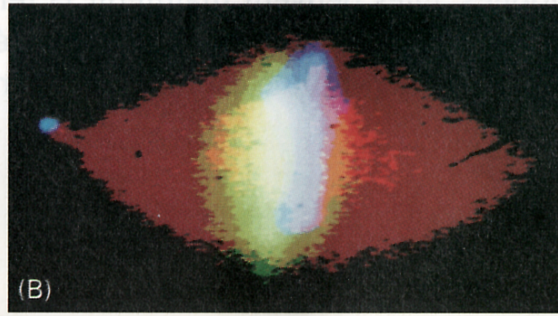
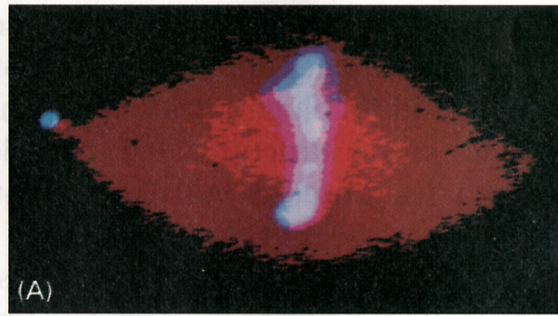

10 μ m

Fuseau de microtubules

Centrosome (1 à chaque pôle du fuseau)

Chromosomes alignés sur la plaque métaphasique

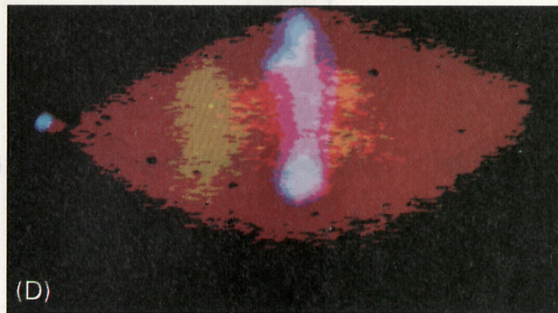
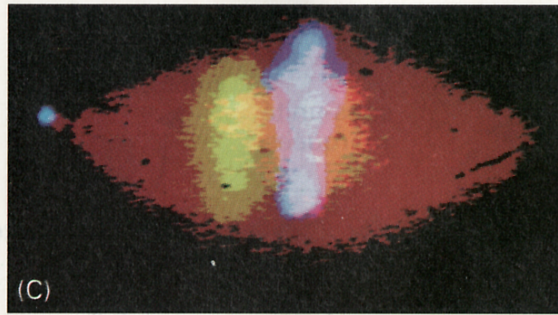
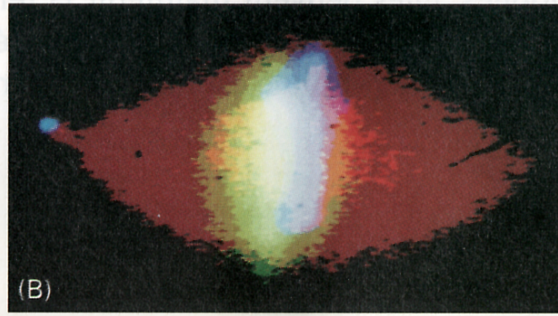
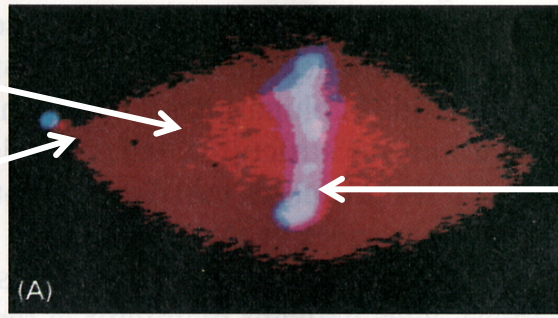

10 μ m

photoactivation

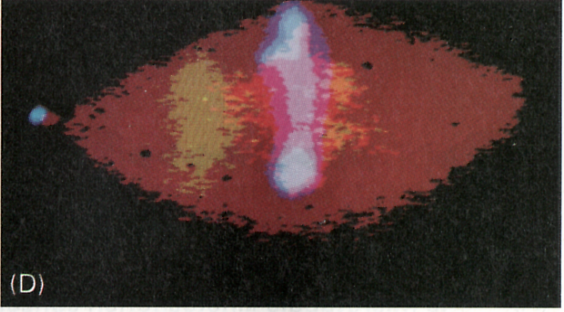
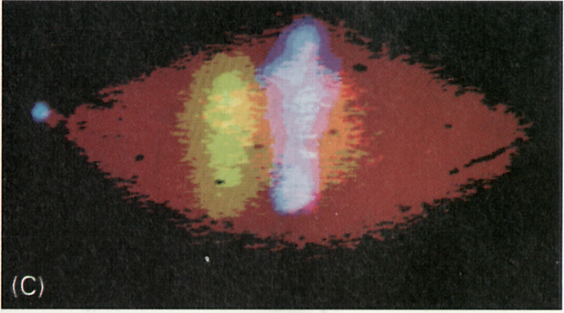
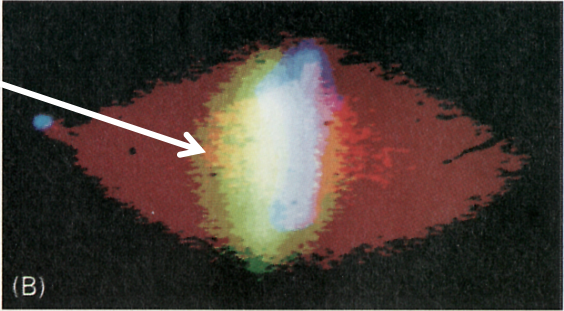
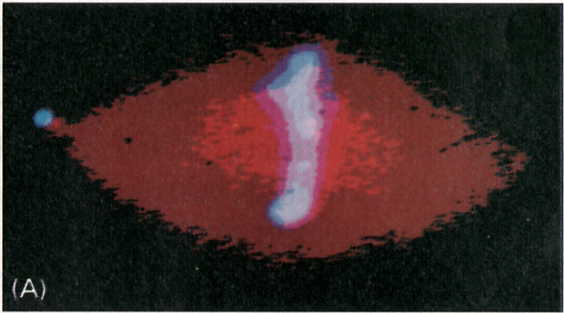

10 μ m

Photoactivation à $t=0$.

UV

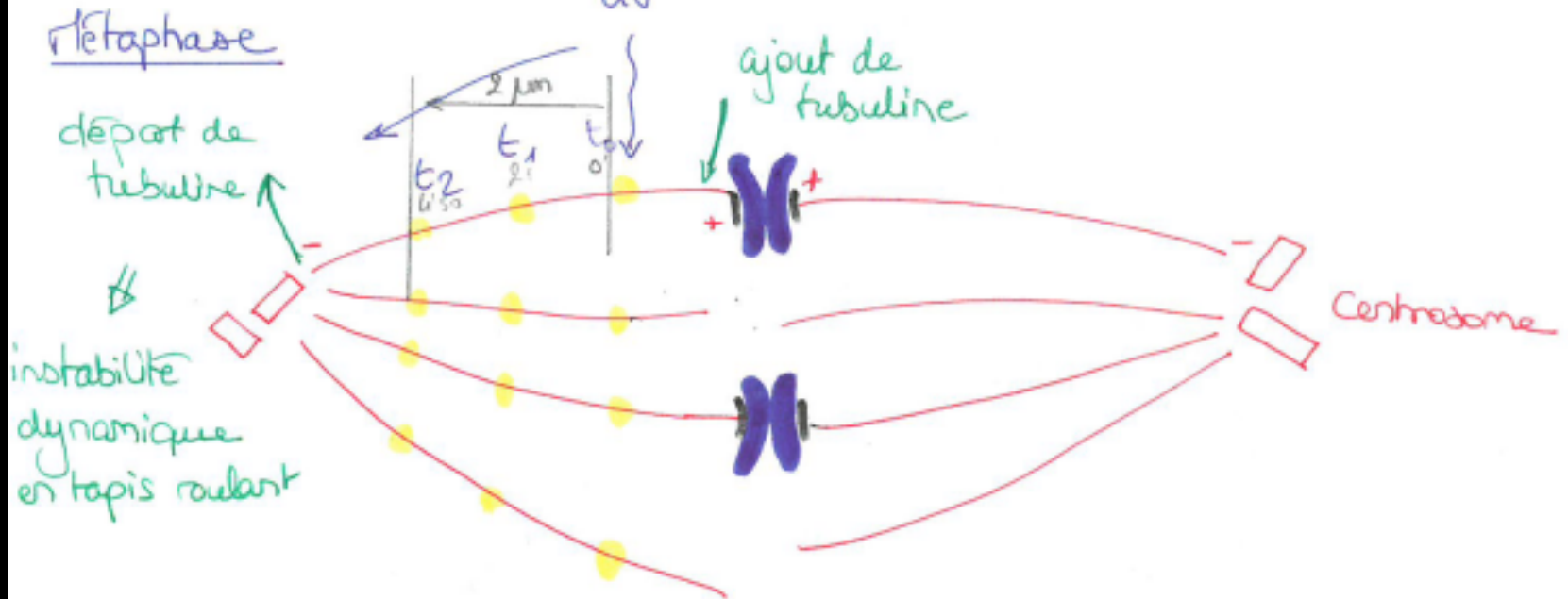

départ de tubuline
↔
instabilité dynamique en tapis roulant

ajout de tubuline

Centrosome

longueurs constante des microtubules
chromosomes alignés sur plaque métaphasique

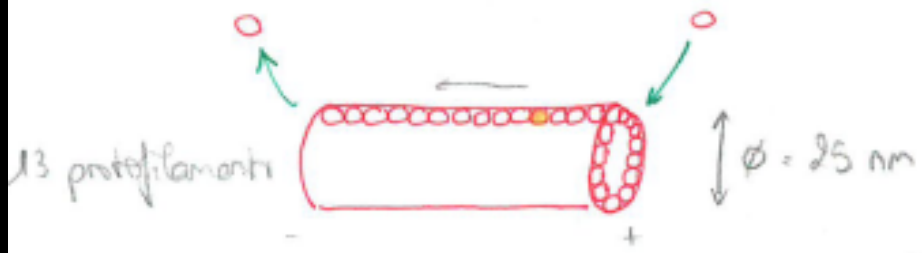

changement de

A metaphase spindle formed *in vitro* by adding *Xenopus* sperm to an extract of *Xenopus* eggs (see Figure 17-9) has incorporated three fluorescent markers: rhodamine-labeled tubulin (*red*) to mark all of the microtubules, a *blue* DNA-binding dye that labels the chromosomes, and **caged-fluorescein-labeled tubulin, which is also incorporated into all of the microtubules but is invisible because it is nonfluorescent until activated by ultraviolet light.** (A) The distribution of the chromosomes and microtubules in the spindle. (B) A beam of ultraviolet light was used to uncage the caged-fluorescein-labeled tubulin locally, mainly just to the left side of the metaphase plate. Over the next few minutes (after 1.5 minutes in C, after 2.5 minutes in D), the uncaged fluorescein-tubulin signal is seen to move toward the left spindle pole, indicating that tubulin is continuously moving poleward, even though the spindle (visualized by the *red* rhodamine-tubulin fluorescence) remains largely unchanged. The caged fluorescein signal also diminishes in intensity, indicating that the individual microtubules are continually depolymerizing and being replaced.

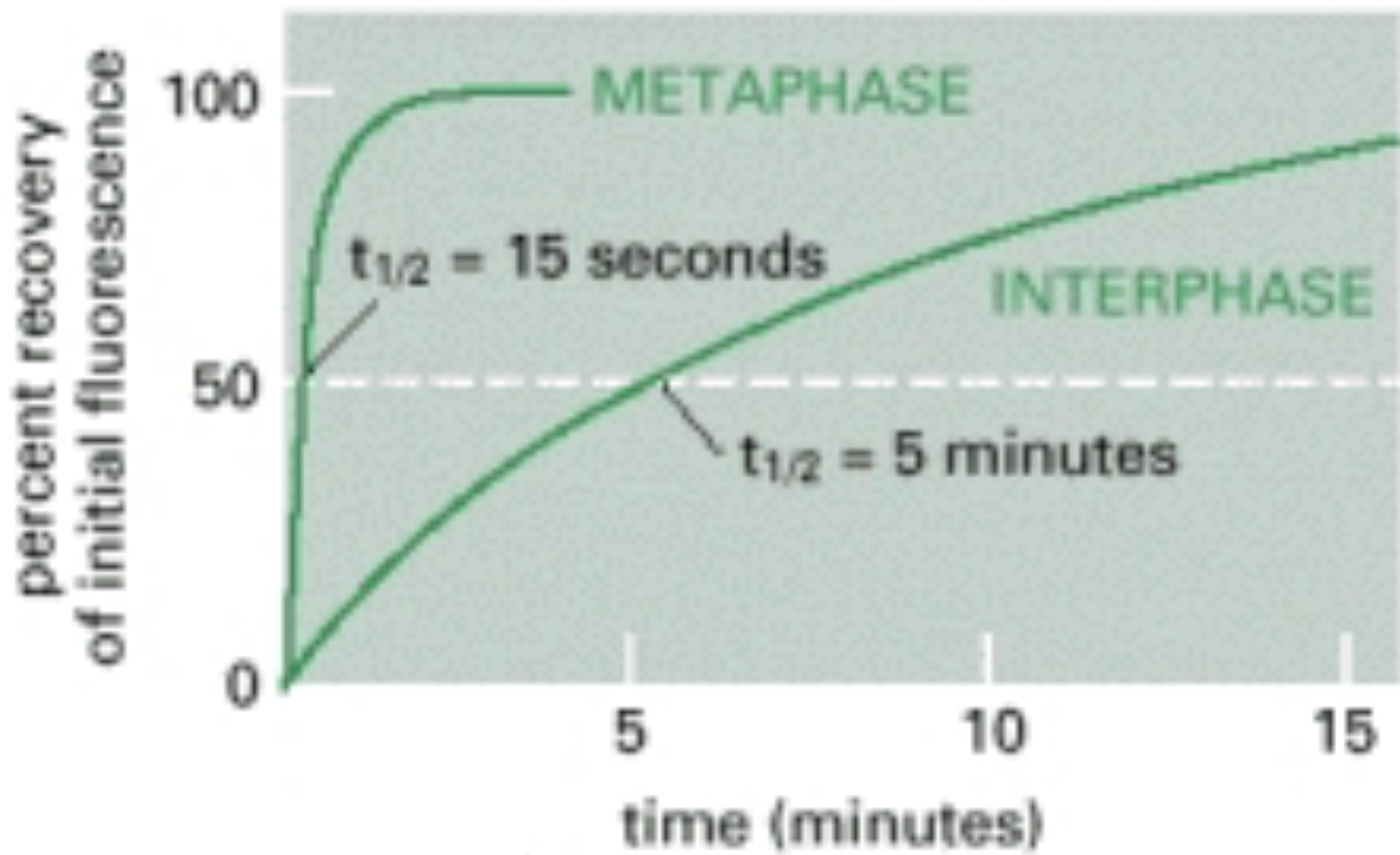

Étude montrant que les microtubules dans une cellule en phase M sont beaucoup plus dynamiques, en moyenne, que les microtubules en interphase. On a injecté, dans des cellules de mammifères en culture, de la tubuline qui a été liée de façon covalente à un colorant fluorescent. Lorsque la tubuline fluorescente est totalement incorporée dans les microtubules d'une cellule, toute la fluorescence d'une petite région est éteinte par un faisceau laser intense. La récupération d'une fluorescence normale dans la région éteinte des microtubules, provoquée par l'échange de leurs sous-unités de tubuline éteintes contre de la tubuline fluorescente non éteinte à partir du pool soluble, est ensuite enregistrée en fonction du temps. On pense que le temps $t_{1/2}$ nécessaire pour que 50 p. cent de la fluorescence soient récupérés est égal au temps nécessaire pour que la moitié des microtubules dans cette région se dépolymérisent et se reforment.

Microtubules in an M-phase cell are much more dynamic, on average, than the microtubules at interphase. Mammalian cells in culture were injected with tubulin that had been covalently linked to a fluorescent dye. After the fluorescent tubulin had become incorporated into the cell's microtubules, an **intense laser beam was used to bleach all the fluorescence in a small region**. The recovery of fluorescence in the bleached region of microtubules, caused by their replacement by microtubules formed from unbleached fluorescent tubulin from the soluble pool, was then monitored as a function of time. The time for 50% recovery of fluorescence ($t_{1/2}$) is thought to be equal to the time required for half of the microtubules in the region to depolymerize and re-form.

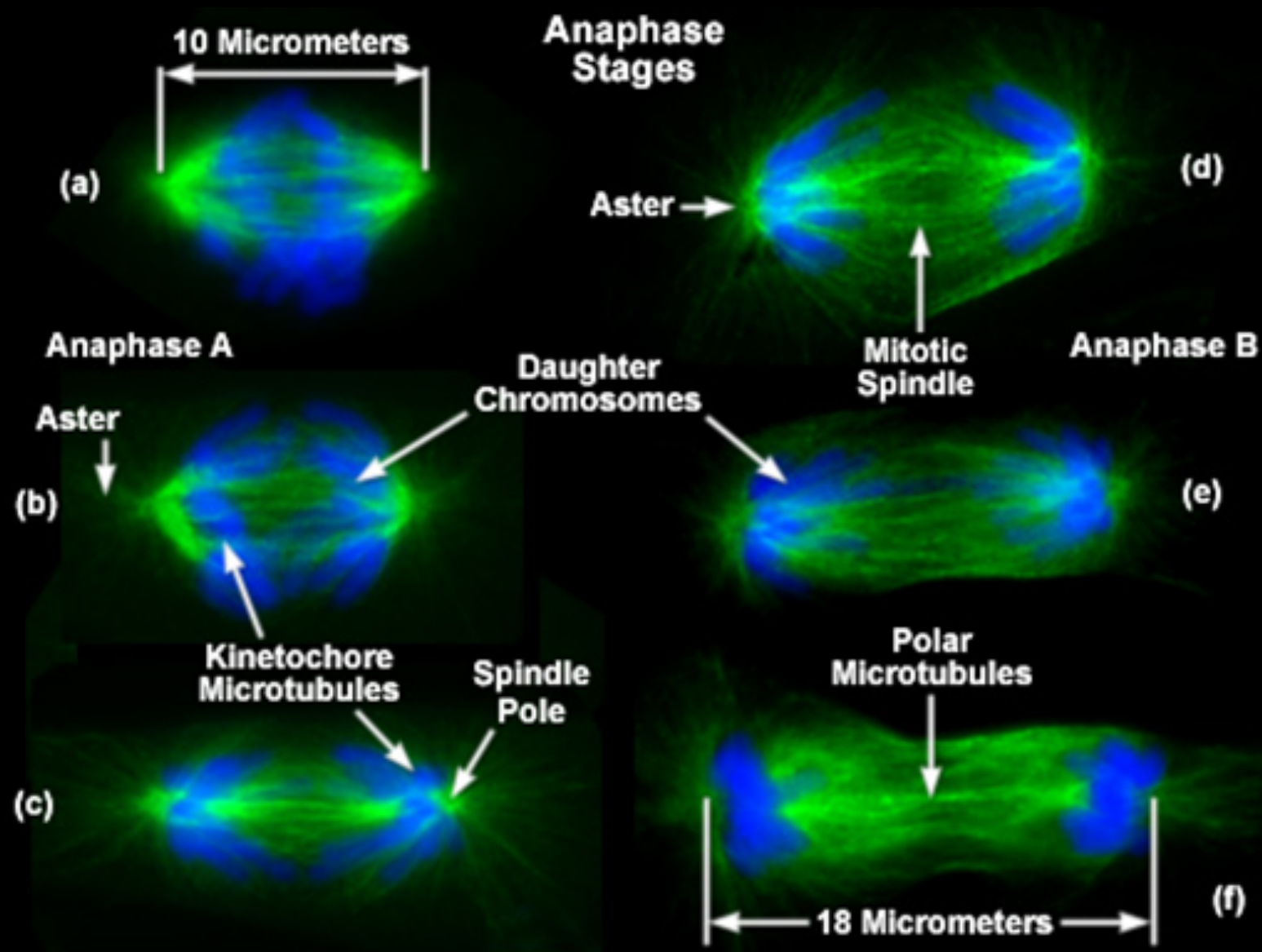

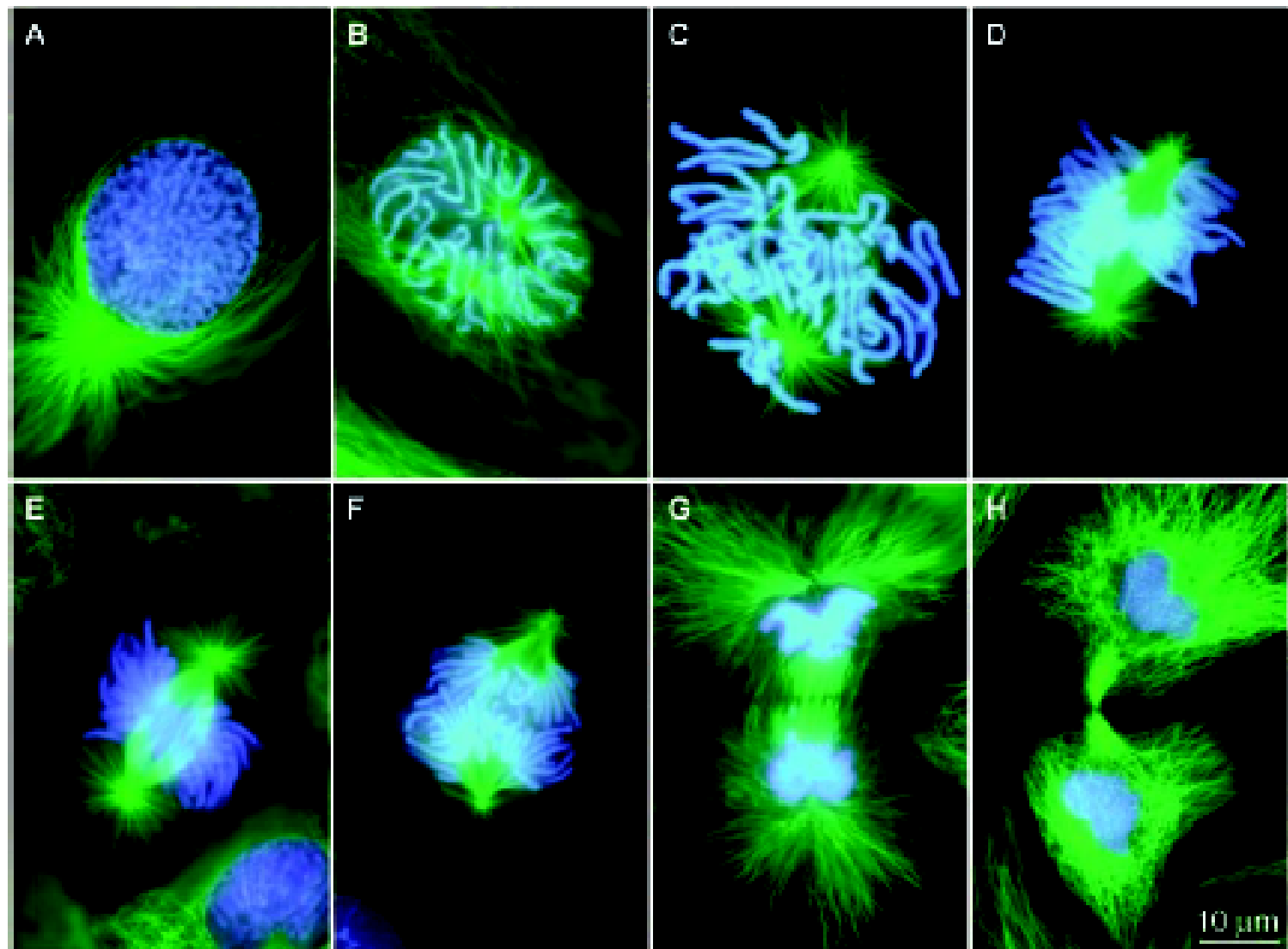
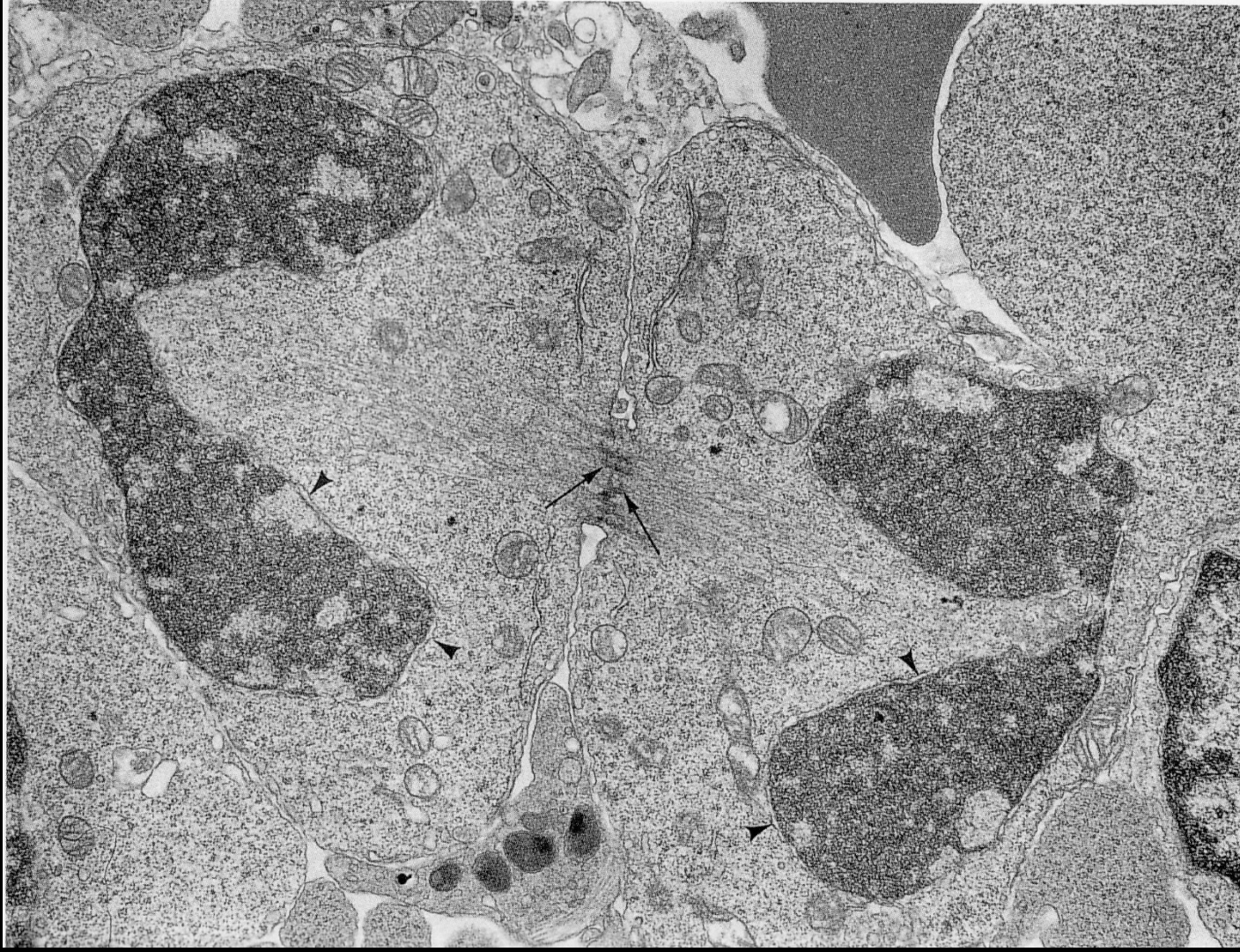
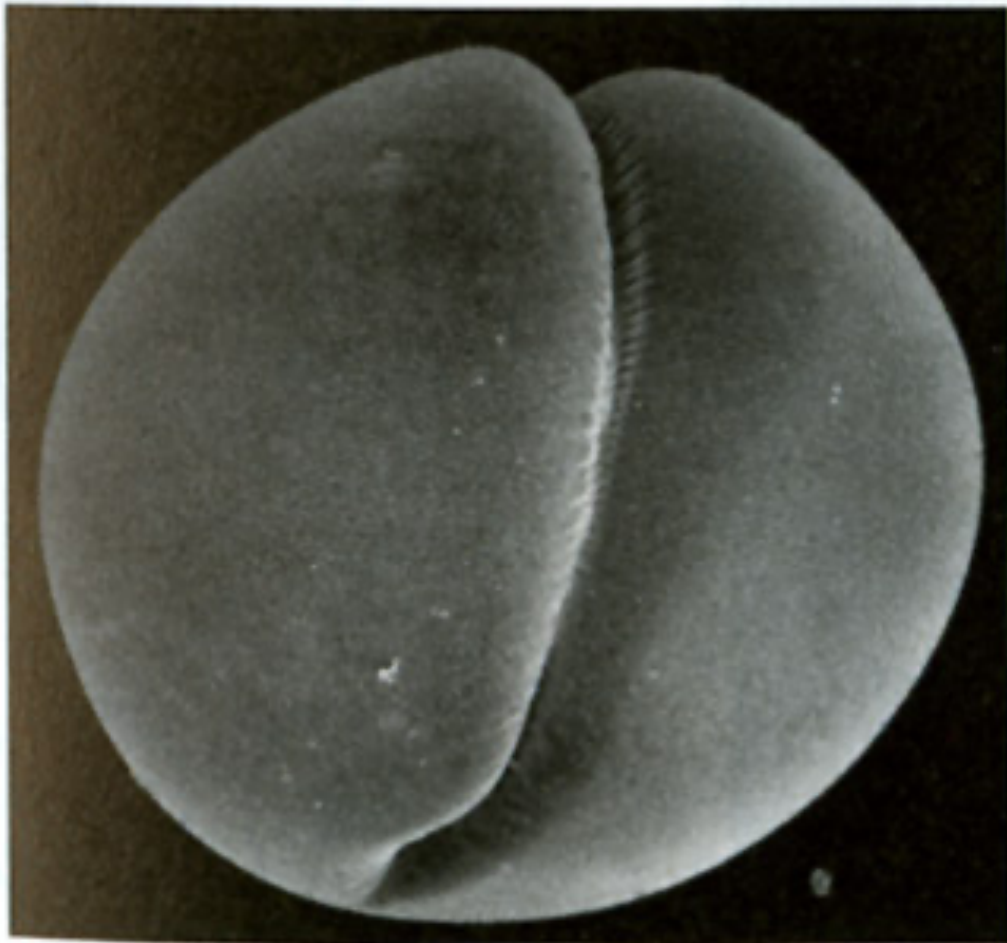

Fig. 3. (A to H) Fluorescence micrographs of mitosis in fixed newt lung cells stained with antibodies to reveal the microtubules (green), and with a dye (Hoechst 33342) to reveal the chromosomes (blue). The spindle forms as the separating astral MT arrays, associated with each centrosome (A to C), interact with the chromosomes. Once the chromosomes are segregated into daughter nuclei (F and G), new MT-based structures known as stem-bodies form between the new nuclei (G). These play a role in cytokinesis (H). Compare with Fig. 1.

CARACTERISTIQUES CELLULAIRES
DES DIVISIONS CELLULAIRES :
la cytotodiérèse = cytokinèse



MIC.: 26 400x



(A)

200 μm



(B)

25 μm

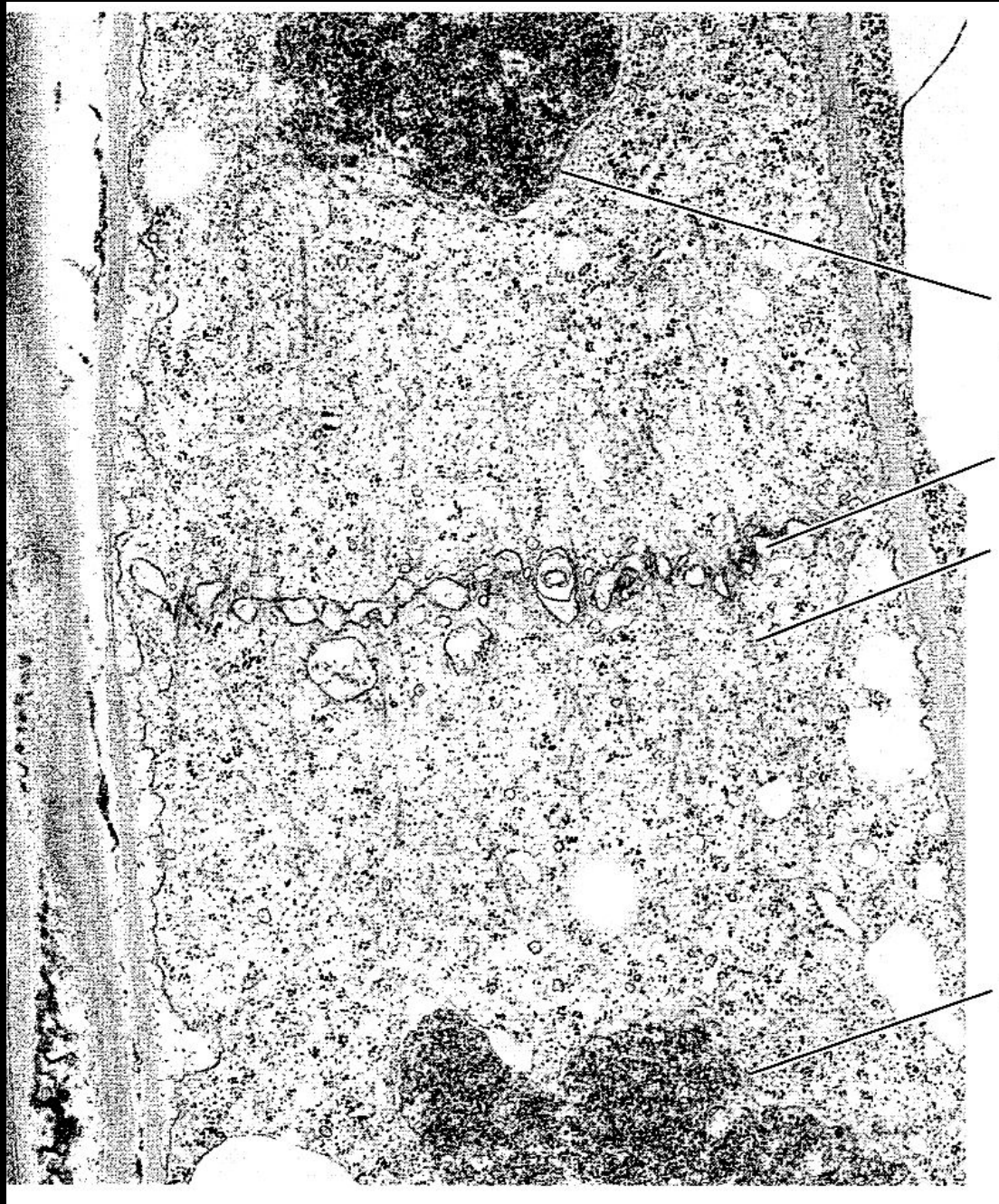

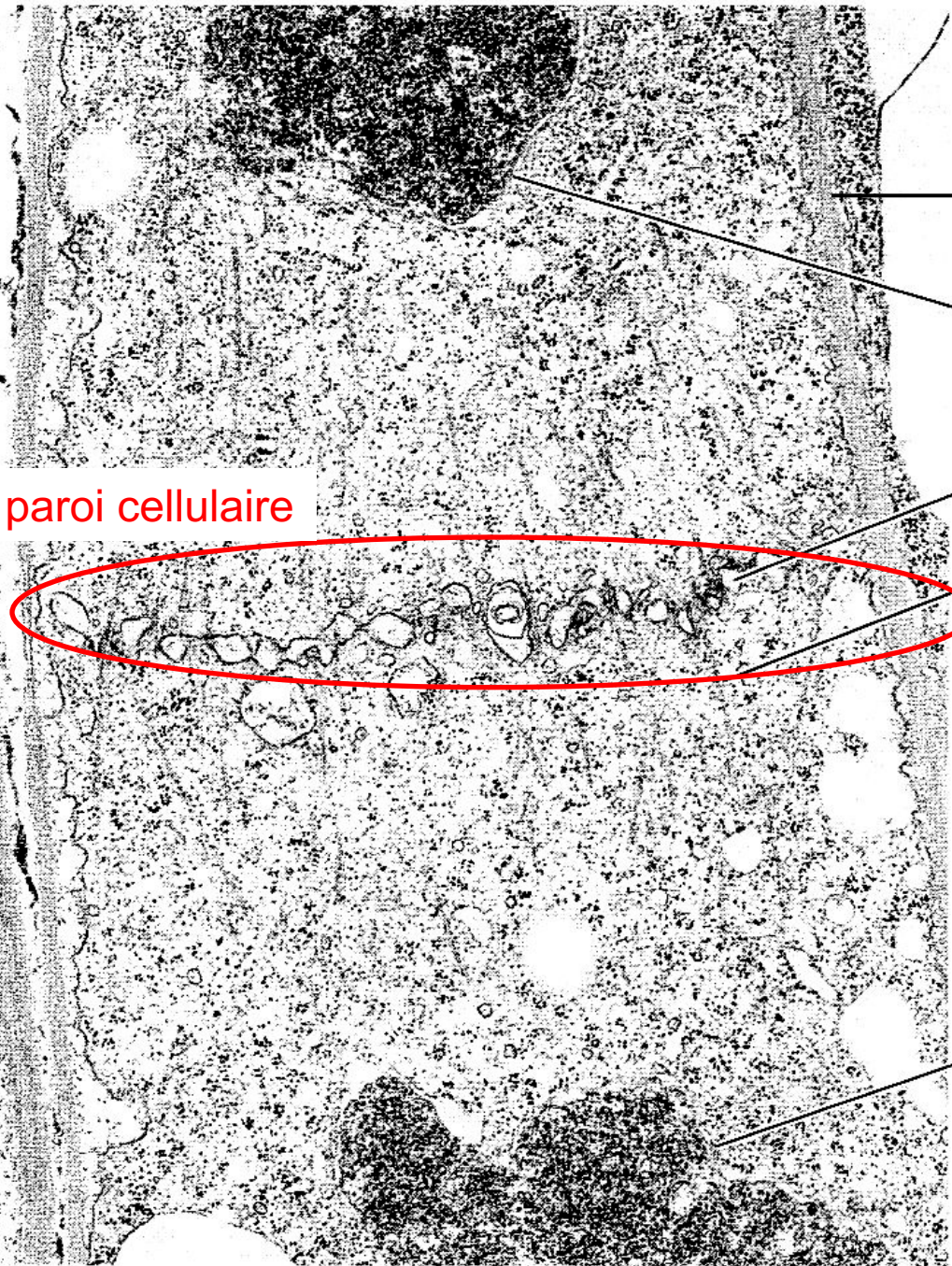

paroi

Noyau

Vésicules
golgiennes
Microtubule

phragmoplaste

Future paroi cellulaire

Noyau

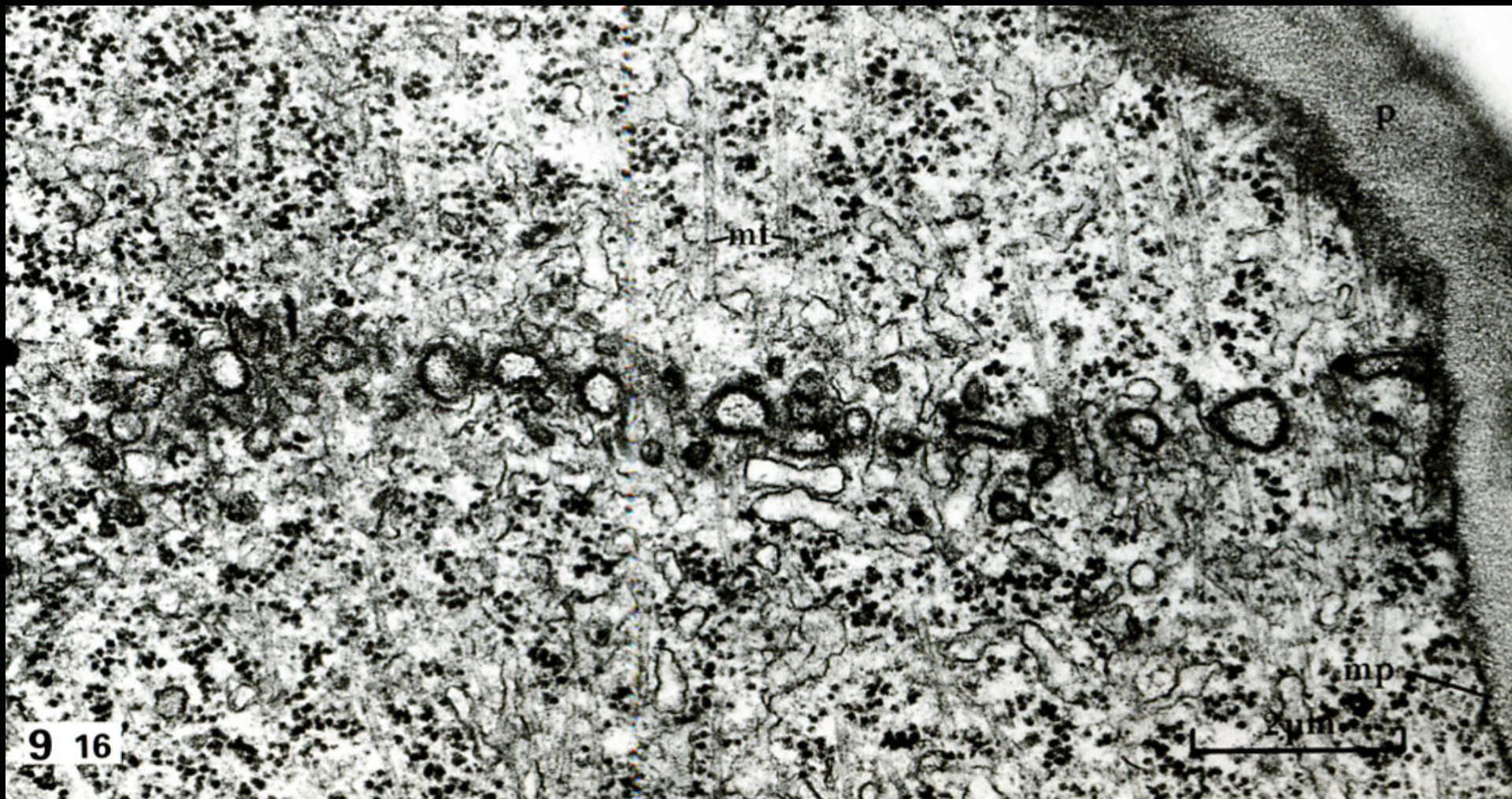

Phase G₂

Télophase

Cytocinèse

Phase G₁

